

Solvent Recyclers – SR Series

Models: SR240/SR240V

User Manual



LR3466

QPS Listed Mark – Canada / United States

Conforms to UL 2208

Certified to CSA C22.2 No. 30

Revision: December 2nd 2025

Kresco

Address: 1404, avenue de la Gare, Mascouche, QC J7K 2Z2

Phone: (877) 757-3726 • Email: info@krescosolutions.com • Website: krescosolutions.com

TABLE OF CONTENTS

SOLVENT RECYCLERS SPECIFICATIONS	4
GENERAL SAFETY RULES.....	5
INSPECTION AND ACCEPTANCE.....	5
GENERAL SAFETY RULES	6
UNIT USE AND CARE.....	7
RISK OF FIRE.....	7
ENVIRONMENTAL CONDITIONS FOR WHICH THE EQUIPMENT IS DESIGNED	8
OVERVIEW OF KRESKO SOLVENT RECYCLERS	8
HOW IT WORKS DIAGRAM.....	9
SOLVENT DISTILLATION PROCESS	9
OBJECTIVES OF THE DISTILLATION PROCESS	10
WARNINGS.....	12
ENVIRONMENTAL PROTECTION.....	12
INSTALLATION AND STARTING OPERATIONS	13
INSTALL ONLY IN A VENTILATED AND SAFE AREA.....	13
INSTALLATION GUIDELINES	13
ADDITIONAL INSTALLATION STEPS FOR VACUUM ASSISTED UNITS	13
ELECTRICAL CONNECTIONS.....	14
INSTALLATION LAYOUT DRAWINGS.....	14
KEYBOARD OPERATIONS.....	15
KEYBOARD OPERATIONS (CONT'D).....	16
CONVERTING BETWEEN CELSIUS AND FAHRENHEIT MODE.....	16
STARTING PROCEDURES.....	17
1. PREPARATION	17
2. PLASTIC BAG INSTALLATION	17
3. FILLING UP THE SOLVENT RECYCLER.....	18
TEMPERATURE AND CYCLE TIME SELECTION	19
TEMPERATURE AND CYCLE TIME SELECTION (CONT'D)	20
DURING THE DISTILLATION CYCLE.....	21
ELIMINATION OF FOAM PRODUCED DURING THE DISTILLATION PROCESS.....	21
END OF CYCLE	21
OPTIONAL AUTOMATIC FILLING/TRANSFER SYSTEM	22
HOW IT WORKS DIAGRAM.....	22
KEYBOARD COMMANDS.....	22

IMPORTANT ADVICE	23
SUPPLIED PARTS (BOX IN THE BOILER)	24
SOLVENTS LISTING AND PROCESS PARAMETERS	24
FLAMMABLE SOLVENTS (Vacuum System Not Required)	25
FLAMMABLE SOLVENTS (Vacuum System Required)	26
NON-FLAMMABLE CHLORINATED SOLVENTS (Vacuum System Required)	26
OPTIONAL VACUUM ASSISTED DISTILLATION	27
EXAMPLE OF VACUUM ASSISTED SOLVENT DISTILLATION	28
OPERATING PRINCIPLES - VACUUM DISTILLATION	30
OPERATING METHODS	30
TROUBLESHOOTING	31
ERROR CODES	31
TROUBLESHOOTING CHART	31
MAINTENANCE	35
THERMIC OIL CHANGING PROCEDURES	36
COVER GASKET REPLACEMENT PROCEDURES	37
SPARE PARTS LIST	39
THERMIC OIL	39
COVER SEALS	39
PLASTIC SLUDGE BAGS	39
FOAM BREAKER	40
COMMON REPLACEMENT PARTS	41
SIDE VIEW	42
SR120/SR180 BOILER HOUSING	43
POWER SUPPLIES	44
OPTIONAL FEATURES	45
ELECTRICAL DRAWINGS	49
PNEUMATIC DIAGRAMS	53
WARRANTY STATEMENT	55
ABOUT KRESCO	56

SOLVENT RECYCLERS SPECIFICATIONS

SPECIFICATIONS	SR240 / SR240V	
General Specifications		
Units System	Imperial	Metric
Geometrical Boiler Capacity	73 US Gal	292 L
Useful Boiler Capacity	63 US Gal	240 L
Operating Temperature	104°-360°F	40°-180°C
Solvent Protection	Class 1, Div. 1, Group D	
Solvent Temperature	Class 310°C / 590°F	
Absolute Operating Pressure	223 – 1,000 hPa	
	170 –760 mmHg	
	-0.223 – 1 bar	
Relative Operating Pressure	-776 – 0 hPa	
	-590 – 0 mmHg	
	-0.776 – 0 bar	
Time Per Distillation Cycle	3.5 to 4.5 hours (estimate)	
Yield	85% to 97%	
Cooling System	Motor Fan 1 hp	
Boiler Material	Stainless steel AISI 304	
Cover Material	Stainless steel AISI 304	
Condenser Material	Copper (standard) / Stainless steel (optional)	
Thermic Oil Capacity	Refer to the nameplate	
Warranty	Standard: 12 months. Extension: 12 months extension with returned warranty card on parts only.	
Electrical Requirements		
Voltage	480V/600V - 3 Ph - 60 Hz	
Power Consumption	18,000 W	
Nominal Amperage (480V/600V)	24.8 A / 19.5 A	
Location Non-Classified Area	General purpose disconnect Min. 5 ft away from unit Min 18" off the floor	
Location In Mixing Room / Classified Area	Explosion proof disconnect required	
Air Requirements (for Vacuum Assisted Unit Only)		
Airline Diameter	3/8" - Use straight connectors only	
Air Requirements	5 cfm @ 100 PSI (factory set at 85-90 PSI)	
Dimensions		
Length	47"	1,194 mm
Width	83"	2,098 mm
Height	80"	2,022 mm
Weight	1,750 lb.	586 kg

GENERAL SAFETY RULES

DANGER AND WARNING LABELS

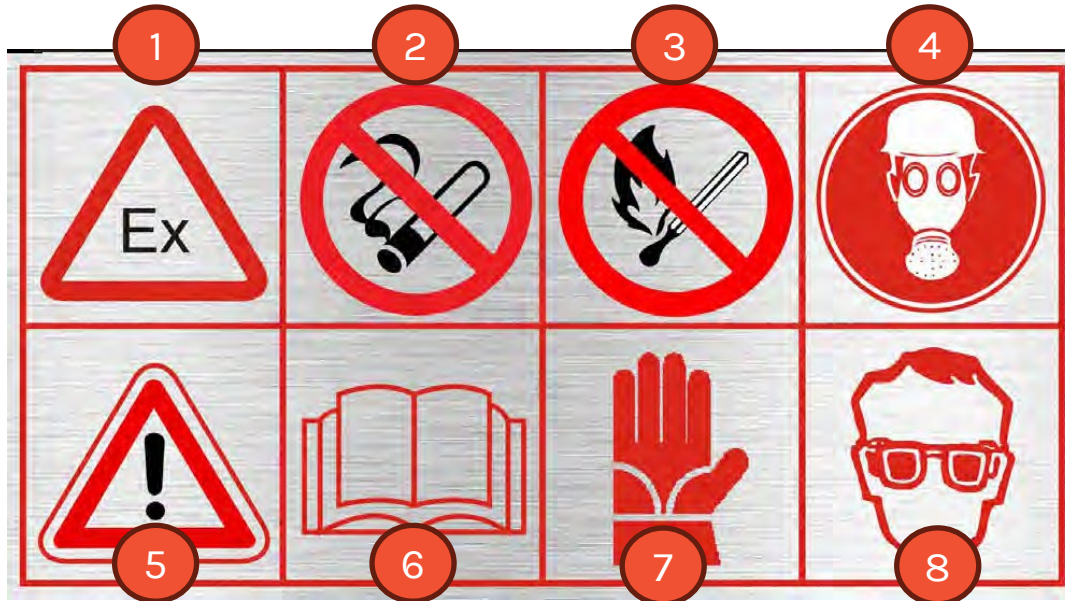

1. Presence of flammable vapors and solvents
2. No smoking or metal grinding nearby
3. Keep away from flames
4. Wear breathing mask
5. Observe warnings at all times
6. Read the Instruction Manual carefully
7. Wear rubber gloves
8. Wear protective eyewear before use

WARNINGS

Read and understand operator's manual and all other safety instructions before using this equipment. Failure to follow the SAFETY RULES and other safety precautions described in this document may result in serious injury.

INSPECTION AND ACCEPTANCE

1. Carefully inspect the shipping carton for any signs of transport damage. The damage to the carton often indicates possibility of transport damage to the equipment inside.
2. Carefully remove your Solvent Recycler from the shipping carton and skid.
3. Check your equipment immediately to ensure that it is free of transport damage. Report any transport damage without delay for possible claim procedures. **Kresco** is not responsible for damage to equipment after it leaves our warehouse.
4. Check the equipment list and compare it with the parts you have received. If any parts are missing, contact the supplier you purchased the equipment from.

GENERAL SAFETY RULES

1. **KEEP WORKING AREA CLEAN.**
2. **GUARD AGAINST ELECTRIC SHOCK.** Non-skid footwear is recommended where damp or wet ground may be encountered. A ground fault circuit interrupter protected power line must be used for these conditions.
3. **DRESS PROPERLY.** Do not wear loose clothing or jewelry. They can be caught in the moving parts. Wear protective hair covering to contain long hair.
4. **USE SAFETY EQUIPMENT. THE OPERATOR MUST WEAR PROTECTIVE EYEWEAR** such as safety goggles or glasses with side shields to prevent spatter from coming in contact with his eyes.
5. **THE OPERATOR MUST WEAR PROTECTIVE WATER-PROOF RUBBER GLOVES** to prevent contact between his hands and the products used for cleaning.
6. **STAY ALERT. USE YOUR COMMON SENSE.** Concentrate on what you are doing. Do not operate the unit when you are tired or under the influence of drugs.
7. **DO NOT OVERREACH.** Keep proper footing and balance at all times.
8. **BEFORE CONNECTING THE UNIT** be sure the power is the same as that specified on the nameplate of the Solvent Recycler. With power greater than that specified on the nameplate can seriously injure the user - as well as damage the Unit.
9. **BEFORE STARTING TO WORK** you must wear earing protections, efficient for 80 dB or more.
10. **KEEP CHILDREN AWAY.** Do not let visitors come in contact with the equipment. All visitors should be kept away from the work area.
11. **MAKE SURE THE LIQUID SOLUTION IS NOT «CORROSIVE» OR FLAMMABLE.** Immediately stop the using and replace the solvent whenever you note signs of corrosion on the unit.
12. **AVOID CONTACT WITH EYES OR SKIN.** Wear protective eyewear, gloves, and clothing.
13. **IF EYES COME IN CONTACT WITH SOLVENTS** rinse thoroughly with water.
14. **BEFORE USING THE SOLVENT RECYCLER,** make sure that all safety devices are in perfect operating condition.
15. **BECOME FAMILIAR WITH THE CONTROLS** and their functions before commencing work.
16. **BE CAREFUL** when you load or unload the solvent in the unit. Make sure you do not splash or spill the contents on the workshop floor.
17. **THE OPERATOR MUST PERIODICALLY** check the level of the solvent contained in the fluid container to be sure to not run this pump dry.
18. **DO NOT ALLOW FAMILIARITY GAINED FROM FREQUENT USE OF YOUR SOLVENT RECYCLER TO BECOME COMPLACENT.** Always remember that a careless fraction of a second is sufficient to inflict severe injury to yourself or those surrounding.
19. **DO NOT ALTER OR MISUSE THE UNIT.** Any alteration or modifications is a misuse and may result in serious personal injuries and will automatically void your warranty.
20. **THE INSTALLATION SITE MUST PERMIT PERSONNEL TO EASILY AND QUICKLY MOVE AWAY** from danger zones in case of an emergency.
21. **COMPLY WITH LAWS IN THE COUNTRY** where the Solvent Recycler is installed regarding the use and disposal of the products used to wash clean objects.
22. **DO NOT USE ELECTRICAL OR PNEUMATICAL TOOLS AROUND THE UNIT. AVOID GASEOUS AREAS.** Do not operate portable electric tools in explosive atmospheres in the presence of flammable liquids or gases. Motors in these tools normally spark, and do not scrape or scratch the machine with metal objects; the sparks might ignite fumes.
23. **FIRE EXTINGUISHING SYSTEMS** must be installed in the same room or close to the unit in case of emergency. These appliances must be well maintained and inspected every year by qualified personnel.
24. **DO NOT USE UNSTABLE REACTIVE** avoid distilling solvent that may include unstable reactive, such a nitrocellulose.
25. **THE INSTALLATION SITE MUST PERMIT PERSONNEL TO EASILY AND QUICKLY MOVE AWAY FROM DANGER ZONES IN CASE OF AN EMERGENCY.**

WARNINGS

THINK SAFETY FIRST! Safety is a combination of the operator's common sense, knowledge of the safety and operating instructions and alertness at all times when the unit is being used.

UNIT USE AND CARE

1. **DO NOT FORCE THE UNIT.** It will perform better and safer at the rate for which it was designed.
2. **THE USE OF ANY OTHER ACCESSORIES** not specified in this manual may create a hazard.
3. **CLOSE THE MAIN AIR SUPPLY VALEV AND THE MAIN BREAKER SWITCH BEFORE SERVICING** or when not in use.
4. **DO NOT ALTER OR MISUSE THE UNIT.** These units are precision built. Any alteration or modification not specified is misused and may result in a dangerous situation and will void your warranty.
5. **BEFORE CONNECTING THE UNIT,** to an electrical power, be sure the power is the same as that specified on the nameplate of the Solvent Recycler. With power greater than that specified on the nameplate can seriously injure the user – as well as damage the Unit. If you have doubts, do not connect the unit.

Only a trained repairman should attempt **ALL REPAIRS**, electrical or mechanical. Contact the nearest **Kresco** repair service facility. Use only **Kresco** original replacement parts; any other parts may create a hazard.

RISK OF FIRE

WARNINGS

THIS EQUIPMENT PRESENTS A RISK OF FIRE. This equipment is designed to be used with solvents with a flash point greater than 40°C (104°F). In case of doubt, DO NOT operate the unit and consult a Kresco Technician.

1. This equipment is designed for use only with Mineral Spirits-based solvents (Stoddard solvent) with a flash point greater than 40°C (104°F). DO NOT add any other chemicals to the cleaning agent including, but not limited to, kerosene, fuel oil, gasoline, chlorinated solvents, brake cleaner, or detergents. The use of any other solvents could potentially cause a hazardous condition. Under certain conditions the solvent could burn.
2. For your protection, a fusible link automatically closes the cover of the Solvent Recycler in the event that a fire occurs in the sink work area. The closed cover contains and smothers the fire inside the metal sink. Do NOT leave large objects in the Solvent Recycler or hang anything on the cover that could prevent it from closing in the event of a fire. Do NOT replace fusible link with any other device to hold cover up.
3. IN CASE OF FIRE, use a Type ABC or Type BC fire extinguisher. Do NOT use water. Contact your local fire department

ENVIRONMENTAL CONDITIONS FOR WHICH THE EQUIPMENT IS DESIGNED

1. Indoor location
2. Altitude 6,562 ft max
3. Ambient temperature: 104 °F (40 °C) max
4. Relative humidity: 80 %
5. Main supply voltage fluctuation +/- 10 %
6. To use with noncombustible dust only

OVERVIEW OF KRESKO SOLVENT RECYCLERS

Kresco's line of Solvent Recyclers is the ideal solution for solvent distillation processes in industrial applications with optimal efficiency, safety, and consistent quality.

It provides a controlled environment for the procedure of separating various solvent blends and chemical substances in order to achieve the highest quality standards and process requirements. Depending on the components included in the substance, one should expect recovery rates yielding from 95% to 99.9%!

Typically, our solvent recovery systems consist of a closed-loop system composed of four main components:

- **Boiler:** a strong, 304-grade stainless steel tank fully insulated with 4" polyurethane.
- **Heating System:** explosion-proof electrical heaters and high-efficiency heat transfer oil that can resist up to 210°C (high temperature oil) for optimal indirect heat performance.
- **Coil condenser:** a recirculating fluid piping circulating through a ventilated condenser coil for a fast cool down and condensation process.
- **Vacuum System (optional):** the vacuum system decreases the boiling point of certain solvents by up to 30%, leading to lower energy consumption and a better distillation process overall. This system is required for the distillation of heavier-than-air solvents such as mineral spirits, naphtha, paint thinner, etc.

The process is fully automated and controlled by a Programmable Logic Controller (PLC) interfaced by an intuitive Human-Machine Interface (HMI). You can also choose from a variety of safety and handling options to facilitate the operation and maintenance of the unit.

Through a distillation process, solvent contaminated with paints, pigments, inks, greases, oils, etc. will evaporate, releasing it from its contaminants, and condensate to be collected in its original form in a separate container.

HOW IT WORKS DIAGRAM

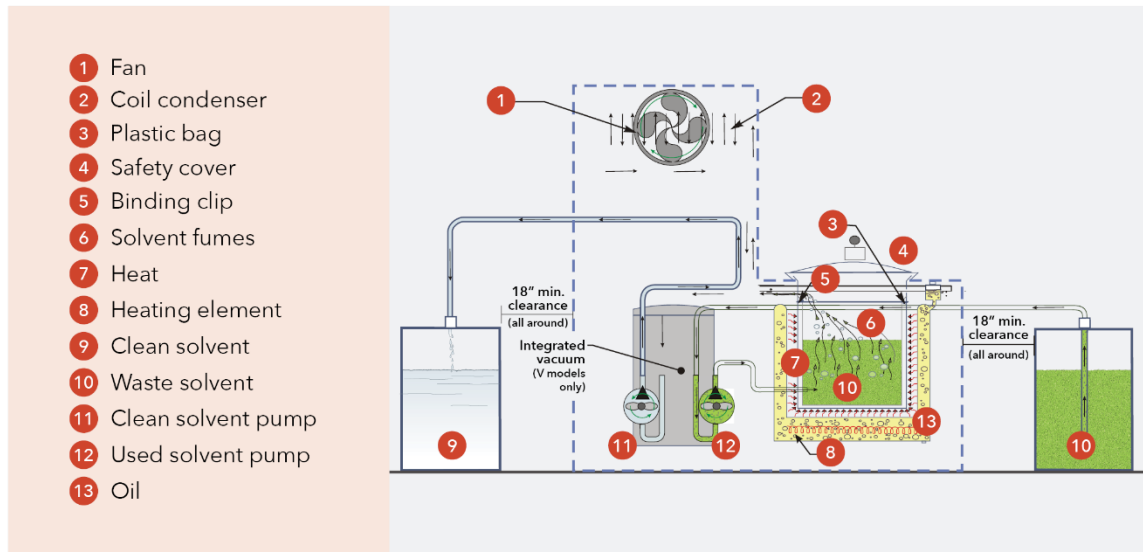

SOLVENT DISTILLATION PROCESS

Basically, the contaminated solvent blend is manually or automatically transferred into a high-resistance polyethylene bag located inside the boiler. The plastic bag will be used to collect the sludge at the end of the process.

The distillation tank must be properly sealed with a lid-lock system. The operator must then set the process parameters using the HMI interface, and all is done!

The evaporation process starts automatically when the solvent blend reaches a specific boiling temperature. The atmospheric pressure inside the distillation tank is then reduced, making it possible to boil the liquid at a lower temperature. That way, the distillation process is safe and efficient.

Solvent vapor then circulates through the condenser where it converts back into the liquid phase, and liquid solvent is then collected in a separate barrel. The whole process takes between four to six hours including the cool down time, and does not require any supervision from the operator.

At the end of the process, the sludge bag should be removed and disposed of in accordance with local laws that may apply in the area in which it is used. The bottom of the distillation tank then needs a little wipe, and a new batch is ready to go.

OBJECTIVES OF THE DISTILLATION PROCESS

The goals that can be achieved with Kresco distillation units are:

1. Solvent recycling with the highest yield possible.
2. Obtaining “special” and not “toxic and noxious” residues.
3. Reducing intervention times and operator discomforts.

Solvent and contamination product topologies are so different that there are no general rules that can apply for all cases. This manual will provide general information that may be useful to your specific situation to which you can adapt as you gain more experience and comfort with using the distillation units.

The products to be recycled normally consist of: Solvent or Reducer + Contaminated Products

Solvent

« Solvent » defines the liquid, which, without reacting chemically, dissolves other substances (solutes), forming a solution.

As every solvent has its own boiling temperature, we must (in order to distill the solvents) set the thermostat at a higher working temperature of about 10°C to 50°C (30°F to 80°F) than the boiling point.

Reducer

A mixture of solvent is defined as a « reducer ». As every solvent component in the mixture has its own boiling temperature, in order to proceed to the distillation of a reducer, set the thermostat at a working temperature of about 10°C to 50°C (30°F to 80°F) higher than the boiling point of the most high-boiling solvent.

Chlorinated Solvents

Chlorinated Solvents are non-flammable solvents, generally utilized for cleaning and degreasing metal surfaces. Normally, these types of solvents are polluted by oil, grease, etc.

Atmospheric pressure distillation of chlorinated solvents will result in a partial recovery, leaving a distillation residue containing about 20% of solvents. This occurs when the oil contents in the boiling solution increases; therefore, the mixture distillation temperature rises.

These solvents are thermalable, meaning that when they exceed their specific critical temperature, they decompose causing the formation of hydrochloric acid. This acidifies the product and therefore cannot be reused. When operating with atmospheric pressure, and reaching this critical temperature, we shall have distilled only 80% of the solvent.

These solvents can be recycled with the assistance of a vacuum system only (SR30V, SR60V, SR120V, SR180V or SR240V). Operating with a vacuum will allow you to achieve a yield of 100%, as you do not reach the critical temperature (vacuum kit is optional).

Liquid Polluting Products

The most common liquid contamination products are: Oil, Ink and Water.

The presence of liquid contamination may (in the distillation phase) drag contaminants into the clean product, leaving traces in the distillate.

For different types of oil and ink with particularly high boiling temperature, this problem normally does not occur and the process of separation may be obtained with a simple distillation.

If there is « water » in the contaminated product, you must recycle with a fractional distillation. This operation is not possible with a simple distillation process.

Unloading a liquid polluting product from the recycler presents no problem. It is possible to obtain a complete separation of the polluting product from the reducer.

This complete separation is not possible when Chlorinated Solvents are to be distilled under atmospheric pressure.

For these solvents it is necessary to proceed with a « vacuum » distillation. This process allows you to obtain a residue without solvent.

Solid Polluting Products

The most common solid polluting products are: Resins, Pigments, Paints, Polymers, Glue, Powder, Grease, etc.

Solid polluting products, according to their nature, already classified as «toxic and noxious» have the advantage (in comparison to liquid contamination products). They can be unloaded into controlled waste dumps, as they do not release toxic substances into the ground. However, this is on the condition that the percentage of solvent will not exceed that of the Concentration Limit (CL) – a value legally stabilized for different types of solvents used in different Countries.

By distillation, and this is another considerable advantage, you can obtain an extremely pure distilled product as there will be no contaminants dragged into the distilled product.

The disadvantage, in comparison with liquid polluting products, is a greater difficulty in cleaning the distillation unit.

Leave a minimal percentage of solvent (3-10%) with the contaminants in the solution of residue, in order to obtain a semi-solid residue, and therefore will be easily discharged.

These percentages, however, are greater than the Concentration Limit (CL) accepted for the disposal in controlled dumps.

WARNINGS

The operating staff must be fully instructed on the use and function of the unit as well as on the correct application of the protection devices. The instructions must be repeated in regular intervals.

- It is essential to keep the Instruction Manual inside the door slot or close to the unit.
- Operator must wear anti-static clothes, avoiding clothes made of synthetic material (nylon, rayon, etc.).
- Open the cover only after the unit has cooled down, with the control board indicating less than 100°C (212°F).
- When unloading residues, it is recommended to use solvent resistant gloves and an anti-vapor mask.
- Do not use any metallic tools as they could provoke sparks.
- The unit must undergo a revision and control according to its grade of use. Maintenance must be carried out by qualified personnel and according to the indications of the Manufacturer.
- It is important to pay attention to the control of the security installations: thermostats, flow controls, thermocouple detectors, switches of safety levels, aspirators, etc.
- Before using a distillation unit, which has been out of use for a long time, it must be checked and brought back into optimal condition in order to guarantee the operator's security at all times.
- According to the type of liquid to be distilled and the kind of operation to be performed, it is important to adopt adequate personal protection rules.
- If you are not using plastic bags, the residues must be cleaned with tools that do not provoke sparks.
- The cover works as a safety valve. If you notice steam leaking from the cover, immediately shut down the recycler and consult pages 31 to 34 « Troubleshooting ». In any case, never modify in any way the parts on top of the cover or block the cover in order to avoid the steam from leaking.
- Nitrocellulose which is an ester of cellulose and nitric acid is a component found in many lacquers, inks, adhesives and cements cannot be recycled. It automatically ignites at 135°-166°C (275°-330°F) and can be extremely volatile.
- It is important to clean the boiler thoroughly after each cycle, as a buildup of residue will stop the transmission of heat and cause a malfunction.
- If repairs are necessary shut off the power supply IMMEDIATELY.
- Do not smoke, cause sparks or use open flames near the recycler.
- This unit is for use in a 40°C (104°F) environment with no forced ventilation. Under these conditions, the unit shall be spaced a minimum space according to national regulation from potential sources of ignition such as electrical receptacles, switches, pilot light fixtures, contacts and other similar equipment that can produce sparks. If the equipment is used in higher ambient temperatures an increase in spacing from sources of ignition shall be considered.
- This unit has been tested for use with the solvents indicated in the instruction manual (see tables on pages 25-26, « Flammable Solvents and Non-Flammable Chlorinated Solvents »)

ENVIRONMENTAL PROTECTION

The user must ensure the protection of the environment so that the recycler cannot be the cause of vapor emissions or odors. The use must ensure that the residues are treated and disposed of according to local jurisdictions and laws that may apply.

INSTALLATION AND STARTING OPERATIONS

INSTALL ONLY IN A VENTILATED AND SAFE AREA

1. **THE UNIT MUST BE INSTALLED IN AN AREA WITH SUFFICIENT NATURAL OR ARTIFICIAL VENTILATION.** If it is placed in a paint mixing room or ventilated enclosed chamber, it is not necessary to install additional ventilation system.
2. **AREAS AND PLACES WITH SUFFICIENT VENTILATION** are those with a capacity of ventilation air with a change of at least ten times per hour. The output of the air vents should be placed so as to remove fumes that cause emerging safe.
3. **A COMPLETE CIRCULATION OF AIR SHALL BE PROVIDED** in case of mechanical ventilation.
4. **MAKE SURE THE EMERGENCY EXIT** is easily accessible at all time.
5. **THE SOLVENT RECYCLER** must be positioned near an exit door.
6. **PLACE A FIRE EXTINGUISHER CLOSE TO UNITY** (for fire types B and C).
7. **KEEP A DISTANCE AT LEAST 24 INCHES** (61 cm) between the unit and any object to enable the Solvent recycler to cool and to be able to perform maintenance as needed.
8. **PLACE THE UNIT ON AN EVEN SURFACE** away from flames, sparks and heat sources.

INSTALLATION GUIDELINES

9. **UNBOLT THE SOLVENT RECYCLER FROM THE PALLET.** Attach a strap or a hoist to the eyelets located on the top of the machine and move it to its final location using a lift truck or a crane.
10. **ENSURE THERE IS ADEQUATE SPACE ON BOTH SIDES OF THE UNIT** for full opening of part loading/unloading and maintenance access doors.
11. **MAKE SURE THE UNIT IS LEVELED AND WELL GROUNDED.** Do not place on a wooden floor or a rubber mat unless a ground wire has been installed.
12. **CONNECT THE MALE ELECTRICAL POWER CABLE** from the Solvent Recycler to a permanent explosion proof electrical line.
 - a. SR240 or SR240V: 480 V 3 Phases 25 A / 600 V 3 Phases 20 A
13. **CONNECT THE GROUND CABLE** located at the back of the Solvent Recycler to a properly grounded component using the supplied crocodile clamp.
14. **PLACE A CONTAINER OF AT LEAST TWICE THE CAPACITY OF THE BOILER** to collect distilled solvent after process cycles:
 - a. SR240 or SR240V: 128 US Gals or more
15. **IF THE UNIT IS EQUIPPED WITH THE SLUDGE MONITORING SAFETY DEVICE**, make sure to use an inline filter on your water supply to trap debris upstream from the valve.

ADDITIONAL INSTALLATION STEPS FOR VACUUM ASSISTED UNITS

Perform these additional steps only if your unit is equipped with a vacuum system.

16. Connect the solenoid inlet to the compressed air circuit with the supplied **3/8"** nylon tube.
17. Set the pressure regulator at 80 PSI (air consumption of 1.13 CFM), unless otherwise indicated by your Kresco technical representative.
18. When distilling flammable solvents, connect the distillate container to the grounding clip.
19. Close the distillate-unloading valve.

ELECTRICAL CONNECTIONS

The Class 1 Division 1 electrical connections must be performed by a certified electrician. For the current and voltage specifications, refer to the nameplate on the right-side panel.

It is recommended to locate the above-mentioned electrical box, at a height of 5 to 6 feet from the floor. An adequate explosion-proof installation must be provided for the solvent recycler and all other components around (for example: protection type Class 1, Div. 1, Group D, with increased safety).

Once the electrical connections are complete, open the main breaker for the recycler and the keyboard light will be « ON ». Each time the power is closed and re-opened, the electronic keyboard will enter a self-test mode.

During 5 seconds, all 5 lights and all 5 digits of 7 segment lights will stay on. Then the keyboard will display its own programming version (example: r 6.0) for a few seconds and then the thermometer light will stay « ON » and the actual temperature of the thermic oil will be displayed.

The control board is « READY » for instructions.

INSTALLATION LAYOUT DRAWINGS

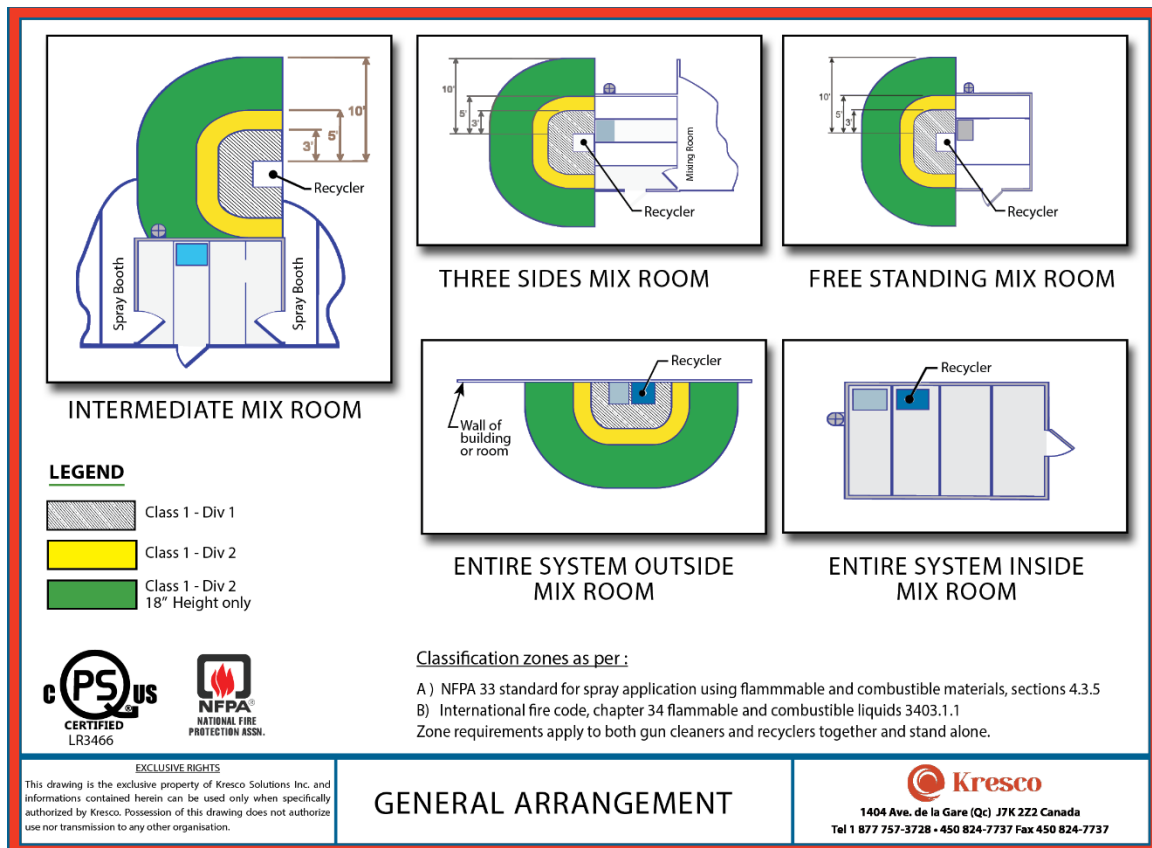

KEYBOARD OPERATIONS

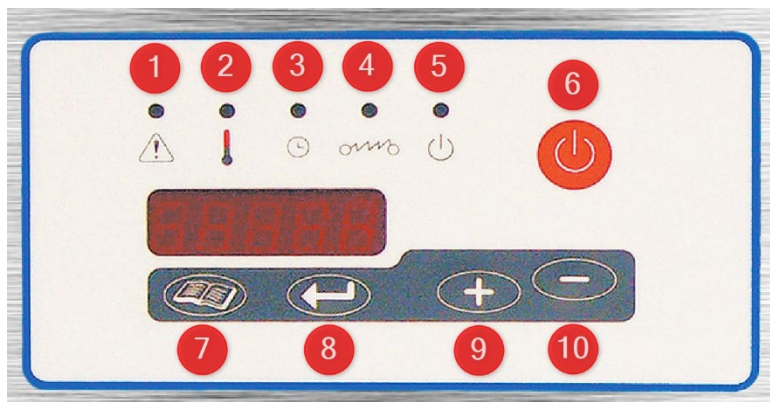

Keyboard Symbols

1. Alarm
2. Temperature
3. Time
4. Electric Heater
5. Start/Stop (light)
6. Start/stop (button)
7. Menu
8. Enter
9. Increase
10. Decrease

The Kresco temperature control board has been designed to control the different cycles during the distillation process. It controls the temperature of the thermic oil, vapors and the distillate solvent coming out of the condenser. It uses this information to maintain a constant temperature, starts the cooling fan to cool the vapors coming off the condenser and stops the cycle if necessary.

Two heat sensors are used to read different temperatures. The thermic oil and the distillate solvent temperatures are captured using two thermocouples (because of high temperatures rising up to 175°C (343°F)). These sensors assure precision of the readings of the temperatures of $\pm 1^\circ\text{C}$ ($\pm 2^\circ\text{F}$).

The Kresco board also display the total number of hours of operation of the recycler. For every 2000 (two thousand) hours of operation, the display code «OIL» will appear to remind you that it is time to replace the thermic oil follow the steps on page 36. The code «OIL» will remain displayed for ten (10) hours and then will disappear.







The display board consists of 5 digits of 7 segments, of 5 independent LEDs (1, 2, 3, 4 and 5) and of 5 touch-tone keys (6, 7, 8, 9 and 10) to operate the recycler. The operator can program the temperature, select the amount of time for the cycle, start or stop the cycle, choose between Celsius or Fahrenheit degrees, and if necessary, display every code to verify the operation of the recycler in case of problems.

The safety devices will stop the cycle in case one of the sensors detects any trouble. The TROUBLE light will be displayed. The recycler CANNOT be re-started until the problem has been resolved.

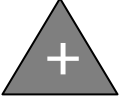
KEYBOARD OPERATIONS (CONT'D)

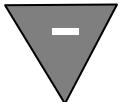
CONVERTING BETWEEN CELSIUS AND FAHRENHEIT MODE.

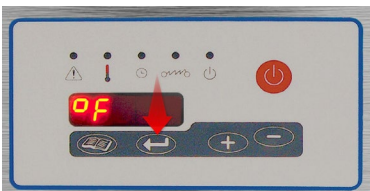
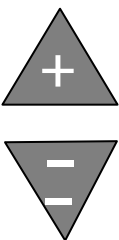
All units manufactured by Kresco are programmed in CELSIUS.

Press	Indication	Result on the Keyboard
	<p>Step 1 - Press (+) Press and hold the Plus (+) sign for 7 seconds</p>	
	<p>Step 2 - Press (-) Press and hold the Minus (-) sign once</p>	
	<p>Step 3 - Press the Arrow (←) Confirm by pressing the arrow (←) sign you are now in Fahrenheit</p>	
	<p>Now set up time and temperature (refer to page 21)</p>	

STARTING PROCEDURES

1. PREPARATION

A) Position a clean solvent container (equal the capacity or greater than the boiler) on the left end side where the clear tube comes from the outlet of the condenser.

B) The clean solvent container must have an air vent to allow normal fill-up.

C) You must use a metallic container, and it must be connected to the ground clip supplied with the unit.

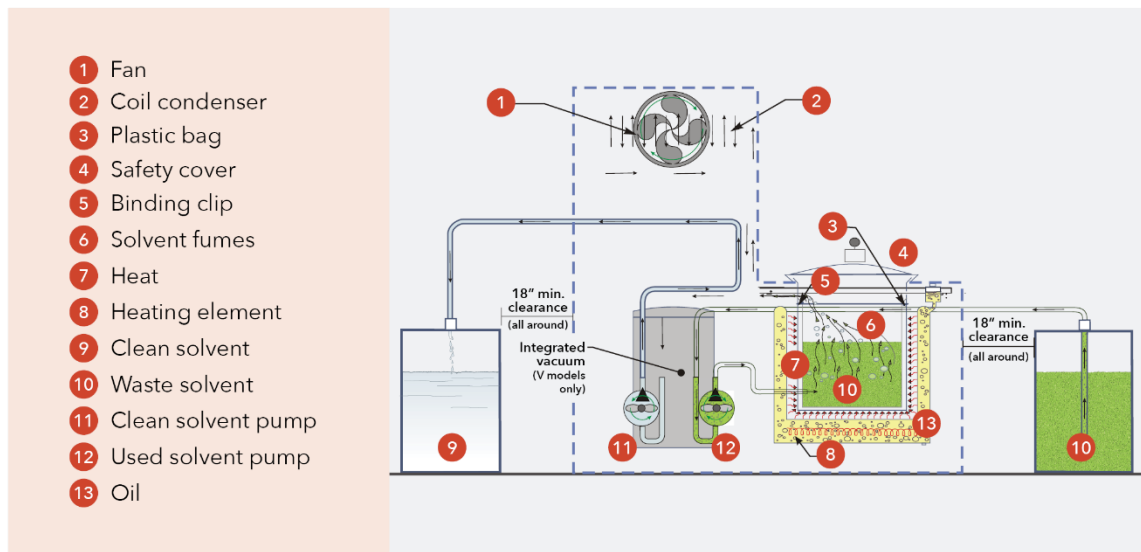

2. PLASTIC BAG INSTALLATION

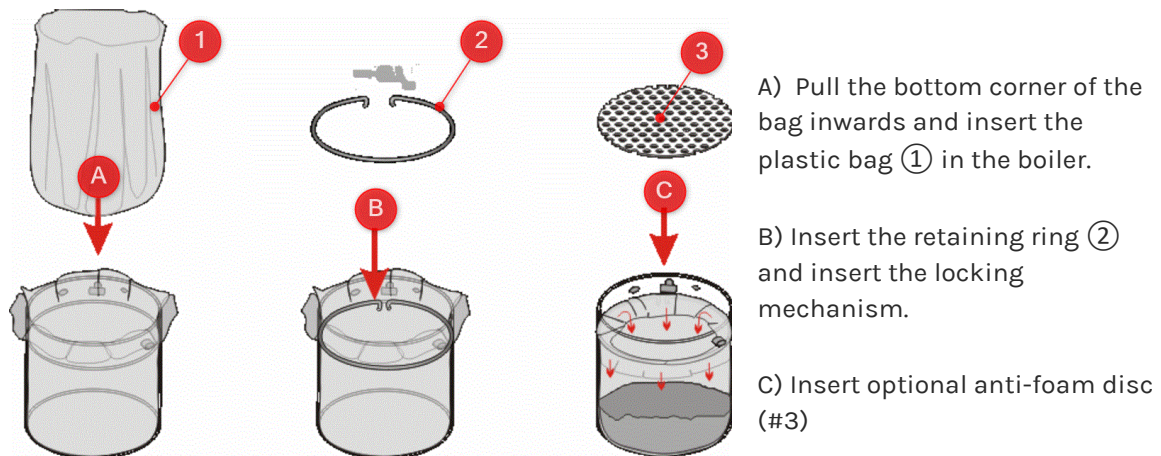

NB Fold the protruding portion of the bags inward as not to cover any spouts.

STARTING PROCEDURES (CONT'D)

Fold the bag inwards to uncover the elbow fitting.



! OVERFLOW PROCEDURE !

If the replacement bag were to block any of the spouts found inside the boiler chamber this would create an unsafe pressure build up. A safety mechanism built into the lid would release the excess pressure and lead to a dangerous situation in which a nearby operator could be burned.

Should you experience this situation, ensure to turn off the cycle switch if safe to do so. If unable to turn off the cycle close the main circuit break and stay away from any solvent which may splash out of the recycler.

IMPORTANT: Wait at least 1 hour before opening the unit and put on gloves and a protective mask before approaching the boiler.

3. FILLING UP THE SOLVENT RECYCLER

A) Open the cover and manually fill the boiler with dirty solvents up to approximately 1 inch (25 mm) below the grooved slot mark indicating the maximum level.

B) Before closing the cover, verify the condition of the lid gasket.

It is recommended to change the thermic oil and the cover seal every 2,000 hours of work or every year whichever comes first. Refer to page 36 for oil change procedures.

C) According to the type of solvent to be distilled, you must use the proper cover gasket.

Using a non-suitable gasket will cause vapors to leak from the cover. Refer to pages 37 to 39 for spare parts and optional components.

STARTING PROCEDURES (CONT'D)

During the boiling phase, some solvents can foam up and lead to a decrease in the quality and quantity of solvent that can be recovered. To avoid this situation an optional anti-foam kit is available.

Pay the utmost attention while the residues are drying. Some polluting products tend to carbonize with a considerable discharge of smoke from the recycler.

In case this occurs, press the (START / STOP) button to end the cycle.

In this case it is not possible to dry the residues at atmospheric pressure; proceeding to the vacuum distillation phase may solve the problem. This technique allows you to operate at a much lower temperature.

Opening the cover before the distillation cycle is complete will cause the gasket to swell. You must wait at least one hour.

D) Close and secure the cover properly. Your cover acts as a safety valve. NEVER modify the cover mechanism and NEVER use any tools to tighten the cover.

E) DO NOT SHAKE OR TILT the recycler during operation.

NOTE: All Kresco Solvent Recyclers are pre-tested and are shipped with thermic oil and cover seal in them. They are ready to be used.











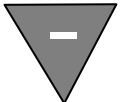

TEMPERATURE AND CYCLE TIME SELECTION

Before starting the cycle, you must select between **CELSIUS** and **FAHRENHEIT** temperatures (refer to page 16). Temperature settings are determined by the **BOILING POINT** of the solvent to be reclaimed. The boiling points shown are for **NEW SOLVENTS**.

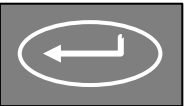
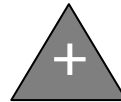
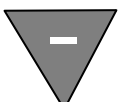
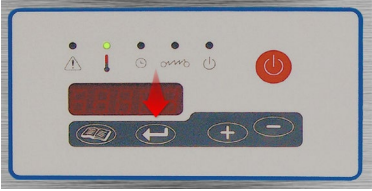
To recycle contaminated solvents, the temperature setting **MUST BE 10°C TO 50°C (50°F to 122°F) MORE** than the stated boiling points starting with 10°C/30°F for the first batch increasing by until 50°C /122°F proper setting is obtained.

NOTE: The temperature setting starting point will vary according to the solvent used and the percentage of contaminants in the solvent.

TEMPERATURE AND CYCLE TIME SELECTION (CONT'D)

Press	Indication	Result on the Keyboard
	<p>Thermometer light is ON. Keyboard will display the actual temperature of the thermic oil.</p>	
	<p>Thermometer light flashes. You have the option to select the temperature for the cycle by pressing keys.</p> <p style="text-align: center;">  or  </p>	
	<p>You have the option to select your own amount of time for the cycle by pressing keys.</p> <p style="text-align: center;">  or  </p> <p>Recycler will automatically stop when time has expired.</p>	
	<p>Clock light is on. The total amount of working hours of the recycler since day one will be displayed. This cannot be changed.</p>	
	<p>Thermometer light is on. Keyboard will display the actual temperature of the thermic oil.</p>	
	<p>Press the START/STOP key. ON light will go on. Electric element will start heating the thermic oil. Element light will go on.</p>	

DURING THE DISTILLATION CYCLE

Every 5 seconds, the keyboard will display 3 different readings:

1. Selected boiling temperature: Thermometer light will flash.
2. Amount of time selected for that cycle: Clock light will flash.
3. Elapsed time since starting the unit: Clock light will be on).

The cooling fan will start turning.

The recycled solvents will start dripping approximately one hour after the start-up.

At the end of the cycle, the ON light will flash and a countdown timer will indicate the remaining time left in the cool down period (starting at 60 minutes and counting down to zero). During the cool down time the heating element will be off but the cooling fan will remain on during the cooling period. When the cycle time has ended, the display panel will indicate "END".

The cooling fan will automatically shut off at the end of the cooling cycle.

ELIMINATION OF FOAM PRODUCED DURING THE DISTILLATION PROCESS

During vacuum distillation some solvents foam with a consequent pollution of the distillate and vapors may leak from the cover.

The problem can be eliminated as follows:

- Utilize anti-foam discs.
- Reduce about 20% of the loading of solvent to be distillate.
- Reduce the compressed air pressure at the vacuum pump. In that way the vacuum will be reduced.
- Reduce the working temperature.
- Wait at least 48 hours after utilizing the solvent before starting the next distillation.

When filling up, pay attention not to pour solvent into the vapor manifold. The first solvent can come out dirty.

END OF CYCLE

The keyboard will display the total elapsed time for that cycle.

All lights will shut off except the ON light.

Wait at least one hour before opening the cover.

You can now remove the residues and clean the bottom of the boiler tank.

Press the stop key.



OPTIONAL AUTOMATIC FILLING/TRANSFER SYSTEM



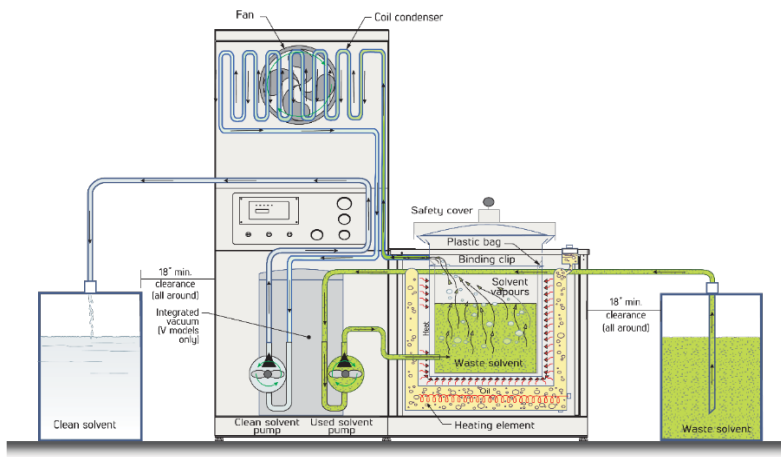

The automatic filling system uses two diaphragm pumps, one to transfer waste solvent into the boiler and the other one to transfer the recovered solvent from the vacuum tank to the container.

The process is controlled by a high-level switch inside the boiler and is assisted by the software fill timer. The solvent transfer hose assembly is equipped with a filter to facilitate the transfer of used solvent.

HOW IT WORKS DIAGRAM



KEYBOARD COMMANDS

Press	Indication	Result on the Keyboard
	<p>Press the START/STOP key. FILL signal will be displayed.</p>	
	<p>Ensure the loading waste solvent valve is open.</p> <p>Press on the ARROW key to start the filling procedure.</p> <p>The transfer pump will start filling the boiler with waste solvent until the level sensor is triggered. Filling procedure will stop.</p> <p>ON light will go on.</p> <p>ELEMENT light will go on and electric element will start heating the thermic oil.</p>	

IMPORTANT ADVICE

1. Use of Anti-Foam Disk

Some solvents during the boiling phase create such a quantity of foam that a correct separation of the solvent from the polluting product is not possible; in fact, in this case, the distillate will still be dirty. To avoid this inconvenience, it will be necessary to obtain an anti-foam kit supplied as an option.

2. Carbonizing Sludge Residues

Pay the utmost attention while the residue is drying; some polluting products with an increase of temperature tend to carbonize with a considerable discharge of smoke from the apparatus.

IN CASE THIS OCCURS, IMMEDIATELY PRESS THE START / STOP KEY TO STOP THE CYCLE.

In this case it is not possible to proceed to drying at atmospheric pressure; the problem may be solved by proceeding to the distillation phase at atmospheric pressure and to the phase of drying under vacuum; this technique will allow you to operate at a much lower temperature.

3. Do Not Open Cover During Distillation

Opening the cover one hour before the distillation cycle is complete will cause the gasket to swell.

4. Do not rotate and shake the unit once loaded or when operating.

5. Smoke Coming Out of the Boiler Cover

The cover acts as a safety valve. In case vapors come out of the cover stop the unit IMMEDIATELY and consult the Troubleshooting Chart on pages 31 to 34.

DO NOT MISHANDLE THE COVER LOCKING SYSTEM OR LOCK THE COVER IN ORDER TO AVOID LEAKING.

6. Oil Expansion Reservoir

Lean the oil expansion reservoir only with a « wet » rag to avoid generating sparks.

SUPPLIED PARTS (BOX IN THE BOILER)

#	Kresco Code	Description
1	FUS-ATDR-TD-25A-600V	Time Delay Fuse ATDR 25 amp 600V
2	FUS-ATDR-TD-30A-600V*	Time Delay Fuse ATDR 30 amp 600V
3	FUS-ATMR-FA-1/2A-600V	Fast Acting Fuse ATDR 1/2 amp 600V
4	FUS-AGC-FA-1/2A-250V	Fast Acting Fuse ATDR 1/2 amp 250V
5	FUS-MDQ-TD-1/4A-250V	Time Delay Fuse MDQ 1/4 amp 250V
6	FUS-MDQ-TD-1/16A-250V	Time Delay Fuse MDQ 1/16 amp 250V

* Only required and supplied for the SR240/240V 480V

SOLVENTS LISTING AND PROCESS PARAMETERS

WARNINGS

The information and data set forth in this catalog or the information disclosed by a representative is for your general information only. Many factors influence the resistance of materials to corrosion, such as temperature, concentration, aeration and contaminants.

Legend: **A** Recommended **B** Not recommended **Blank** Information not available



FLAMMABLE SOLVENTS (Vacuum System Not Required)

SOLVENT TYPE	Distillation Temperature		Temperature Class	Ignition Temperature		Seal Silicone	Condenser Type	
	°C	°F		°C	°F		cop	s/st
Acetone	56	133	T-2	535	995	A	A	A
Alcohol Amyl	145	293	T-2	300	572	A		B
Alcohol Butyl	118	244	T-2	343	649	A	A	A
Methanol	65	149	T-2	440	824	A	A	A
Amyl Acetate	126-155	259-311	T-2	375	707	A	A	A
Benzol (Benzene)	80	176	T-1	498	1040	A	B	B
Butanol (Butyl Alcohol)	118	244	T-2	366	691	A	A	A
Butyl Acetate	128	262	T-2	370	698	A	B	A
Cabinol	65	149	T-2	385	725	A	B	A
Cellosolve Acetate	156	313	T-2	377	711	A	B	A
Cyclohexanone	155	311	T-2	419	786	A	B	A
Ethyl Acetate	79	174	T-2	427	801	A	A	A
Ethyl Alcohol (Ethanol)	79	175	T-2	362	684	A	A	A
Ethyl Benzene	136	277	T-1	466	871	A	A	A
Ethyl Glycol Acetate	156	313	T-2	377	711	A		
Heptane	98	208	T-2	220	428	B	A	A
Iso Amyl Acetate	125-155	257-311	T-2	375	707	A		A
Iso Butyl Acetate	104-119	219-246	T-2	420	788	A		
Iso Butyl Alcohol	111	232	T-2	430	806	A		
Iso Propane	83	181	T-2	400	752	A	B	A
Iso Propyl Acetate	89	192	T-2	460	860	A	A	A
Iso Propyl Alcohol	83	181	T-2	400	752	A		A
Iso Propyl Glycol	143	289	T-2	345	653	A		
Lacquer Solvents	140	284	T-2	535	995	A	A	A
Methyl Acetate	58	136	T-2	454	850	A	B	A
Methyl Cellosolve Acetate	156	313	T-2	377	711	A	B	A
Methyl Ethyl Ketone (M.E.K.)	80	176	T-1	530	986	A	A	A
Methyl Glycol Acetate	137-152	278-305	T-2	380	716	A	A	A
Methyl Isobutyl Ketone (M.I.B.K.)	117	243	T-1	459	858	A	B	A
N. Butyl	118	244	T-2	366	691	A		A
Pentanol	138	280	T-2	327	621	A		A
Propanol	98	208	T-2	371	700	A		A
Propyl Alcohol	98	208	T-2	371	700	A	A	A
Propyle Acetate	101	214	T-2	450	850	A	A	A
Paint Thinner	140	284	T-2	535	995	A	B	B
Sec. Butyl Alcohol	101	214	T-2	390	734	A		A
Toluol	110	231	T-1	480	905	A	A	A

FLAMMABLE SOLVENTS (Vacuum System Required)

SOLVENT TYPE	Distillation Temperature		Temperature Class	Ignition Temperature		Seal Teflon Braided	Condenser Type	
	°C	°F		°C	°F		cop	s/st
Aliphatic hydrocarbons	188	370		253	487	A	A	A
Bottcherin	188	370		253	487	A	A	A
Citrus terpenes	176	349		237	458	A	A	A
D Limonene	176	349		237	458	A	A	A
Dimethylformamide (DMF)	153	307	T-2	445	833	A	A	A
Ether Glycol	210	410		277	531	A	A	A
LO NX (Kodak)	203	398		N/A	N/A	A	A	A
N-Methylpyrrolidone	202	396		N/A	N/A	A	A	A
Varsol	150	302	T-2	351	487	A	A	A
Virosol 225	N/A	N/A		N/A	N/A	A	A	A
White Spirit	150-175	302-374	T-2	353	489	A	A	A
Xylol (Xylene)	144	291	T-1	463	907	A	A	B

NON-FLAMMABLE CHLORINATED SOLVENTS (Vacuum System Required)

SOLVENT TYPE	Distillation Temperature		Temperature Class	Ignition Temperature		Seal Silicone	Condenser Type	
	°C	°F		°C	°F		cop	s/st
1,1,1, Trichloroethane (Methyl Chloroform)	74	165				A		A
1,2,3. trichloropropane	158	317				A		A
Carbon tetrachloride	78	172				A		A
Chloroform	61	142				A		A
Dichloroethylene	37	99				A		B
Ethylene dichloride	84	183				A		A
Isopropyl chloride	40	104				A		A
Methylene chloride	40	106				A		A
Monochlorobenzene	133	273				A		A
n-Propyl Chloride	47	117				A		A
Ortho dichlorobenzene	182	361				A		A
Perchloroethylene	122	254				A		A
Propylene dichloride	98	208				A		A
Tetrachloroethane	147	297				A		A
Trichloroethane	115	239				A		A
Trichloroethylene	92	198				A		A

OPTIONAL VACUUM ASSISTED DISTILLATION



The boiling temperature of the solvents reported on pages 25-26 measured for atmospheric pressure operation of 1,000 hPa (760 mm Hg).

It's well known that by reducing the pressure, the boiling temperature of any substance is reduced.

When vacuum is created inside the distillation appliance, the boiling temperature is considerably reduced.

A distillation vacuum system on your SR30 or SR60 model will reduce boiling temperatures by about 30% leading to less energy consumption and a more efficient distillation performance overall.

Vacuum distillation is recommended in the following conditions:

1. Distillation of Highly Volatile Solvents

When processing solvents with a boiling temperature greater than 70°C (158°F).

Compulsory when processing solvents with a boiling temperature greater than 60°C (140°F). Operating at a higher temperature can create problems on the cover seal.

2. Distillation of Solvents with Ignition Point Close to Boiling Temperature

When processing solvents with ignition point too close to their boiling temperature can create a hazard or the solvent can degenerate and become an acid base and therefore cannot be re-used.

3. Distillation of Chlorinated Solvents

When processing chlorinated solvents, atmospheric pressure distillation allows only a partial recovery of these solvents; at the end of the process the residues will still contain 20% of solvents.

This happens because as the percentage of oil in the solvent increases, so does the temperature.

Chlorinated solvents have specific critical temperatures which when breached provoke the decomposition of the solvents leading to the formation of hydrochloric acid. This process will make the end product unusable.

EXAMPLE OF VACUUM ASSISTED SOLVENT DISTILLATION

Let's take a look at a concrete example of the benefits of the vacuum assistance during a solvent distillation process.

Technical Specifications	Values
Product to be distilled	Perchloroethylene
Distillation temperature at atmospheric pressure	121°C @ 1,000 hPa
Distillation temperature at vacuum condition	84°C @ 223 hPa
Critical temperature of decomposition	150°C

A. Boiling Range of Clean Perchloroethylene at Atmospheric Condition (1,000 hPa)

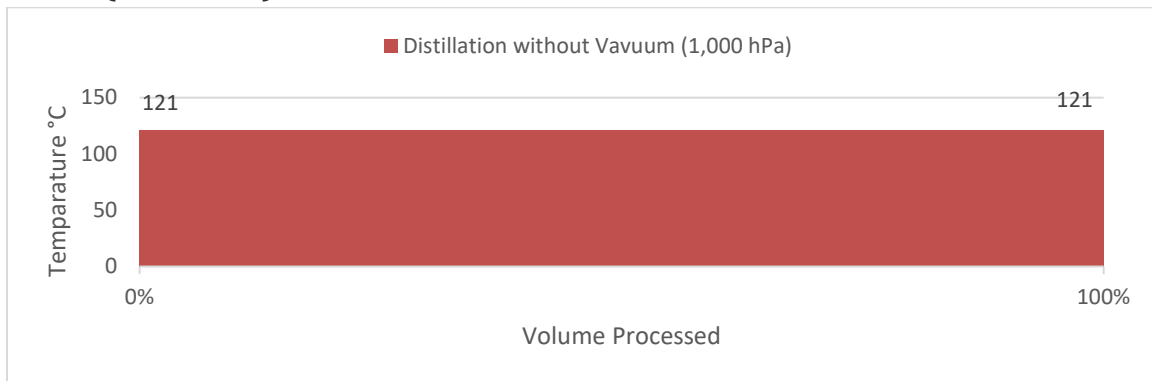

The distillation temperature of a clean solvent remains the same until the process of the whole cycle is complete.

B. Boiling Range of Clean Perchloroethylene at Vacuum Condition (223 hPa)

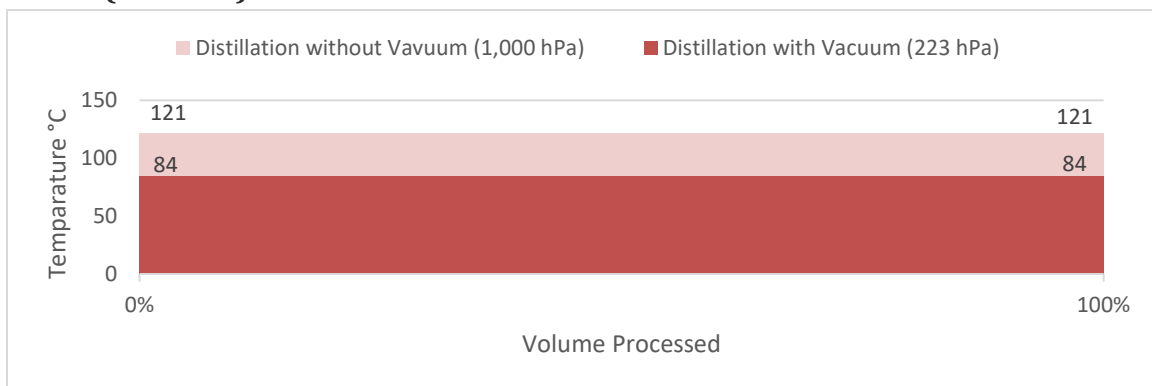

The distillation temperature of a clean solvent remains the same until the process of the whole cycle is complete.

C. Boiling Range of a 90% Perchloroethylene + 10% Oil Blend at Atmospheric Condition (1,000 hPa)

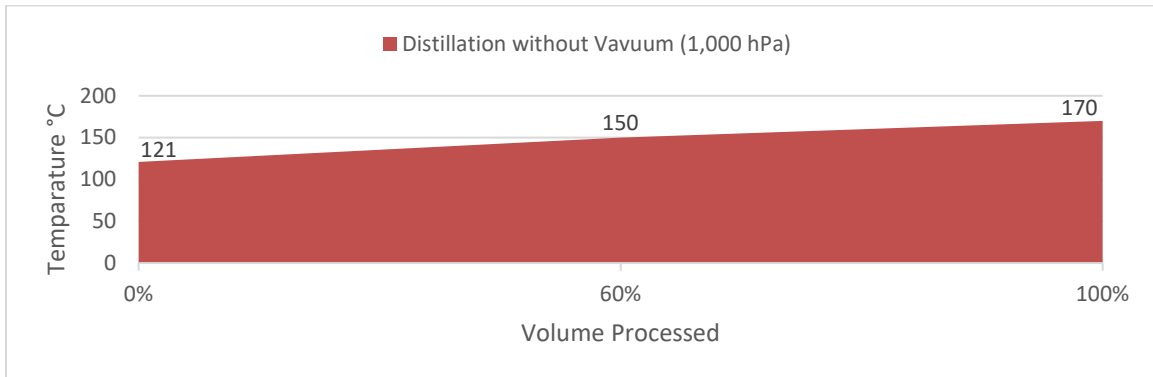

Once a temperature of 150°C (302°F) is reached, which is the critical non-supportable temperature, only 80% of perchloroethylene will be recovered.

The distillation temperature of the contaminated solvents increases during the process; this variation depends on the degree of contamination and on the type of contaminating substances.

D. Boiling Range of a 90% Perchloroethylene + 10% Oil Blend at Vacuum Condition (223 hPa)

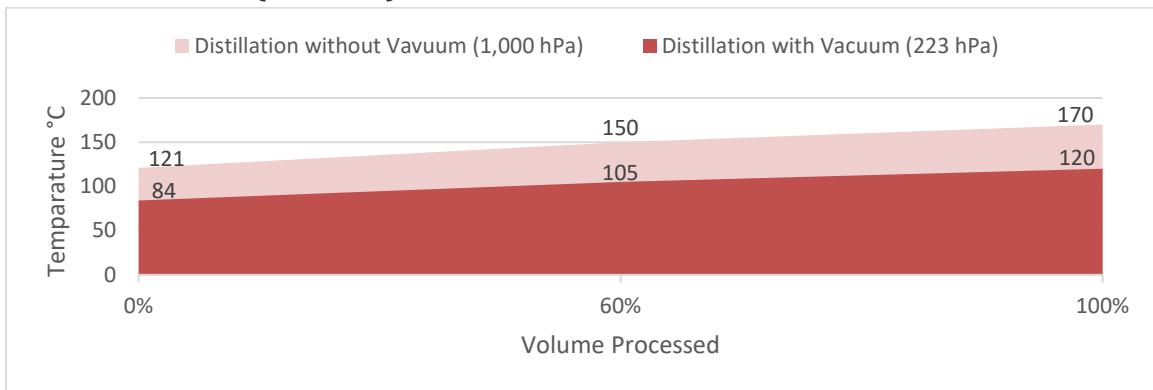

Operating with vacuum condition, 100% of perchloroethylene will be recovered when set at 120°C (248°F) and very far from the critical temperature of 150°C (302°F).

When distilling chlorinated solvents, the vacuum distillation is indispensable; this type of process is also necessary for minimal quantities of contaminants because of two specific reasons:

1. Yields 100%.
2. If the residual oil is contaminated with more than 2% of solvent, waste recycling companies will not accept it.

The distillation temperature of the contaminated solvents increases during the process; this variation depends on the degree of contamination and on the type of contaminating substances.

OPERATING PRINCIPLES - VACUUM DISTILLATION

Before reading this section, it is mandatory to read the previous section regarding the distillation at atmospheric pressure.

Unlike what occurs during atmospheric distillation, the distillation unit and the distillate collection tank are a single body.

A pneumatic vacuum generator joined at the solvent recovery tank provides the creation of the vacuum circuit.

Boiler Condenser Tank

The vacuum generator is fed with compressed air with a pressure of 70-100 PSI with a maximum negative pressure of -27 PSI, -590 mm Hg.

NOTE: WITH VACUUM DISTILLATION IT IS POSSIBLE TO DISTILL SOLVENTS WITH DISTILLATION TEMPERATURE HIGHER THAN 60°C (140°F) AT ATMOSPHERIC PRESSURE.

For example, distilling at vacuum condition the Acetone, which has a distillation temperature of 56°C (133°F) at atmospheric pressure, will reach a boiling point of 39°C (101°F). Considering that the condenser is by air, if the temperature result is higher than 20°C (70°F) you will obtain a partial condensation of the solvent with an emission of Acetone vapor in the air.

OPERATING METHODS

DISTILLATION: AT ATMOSPHERIC PRESSURE
DRYING : AT VACUUM CONDITIONS

When processing solvents with distillation temperature lower than 60°C (140°F), polluted with liquid products.

When processing solvents with distillation temperature higher than 60°C (140°F), polluted with solid products.

In this case the process of the solvent reducer distillation temperatures between 60°-200°C (140°-392°F), and polluted with liquid products.

TROUBLESHOOTING

ERROR CODES

There are 5 (five) ERROR CODES that can be displayed if a problem occurs:

Codes	Explanation
O HI	Thermic oil temperature is too HIGH.
L HI	Recycled solvent temperature is too HIGH.
S HI	Recycled sludge temperature is too HIGH (OPTIONAL).
P-OFF	Water pressure is LOW or vacuum negative pressure is LOW.
FILL-O	FILL NOT COMPLETED after 20 minutes.

The **ERROR CODES** can be erased by touching the + key (9) for each code.

TROUBLESHOOTING CHART

Symptoms	Possible Causes	Resolutions
Unit heats but does not distill.	Boiler is dirty.	Clean the boiler.
	The solvent boiling point is higher than the temperature indicated on the control panel.	Set a higher temperature on the control panel.
	The solvent boiling temperature is higher than the recyclers highest temperature setting.	Use a solvent with a lower boiling temperature or vacuum distill with the suitable kit (optional).
	Thermic oil is worn out.	Change thermic oil.
	Lack of thermic oil.	Add thermic oil.
Smoke comes out from the cover.	Polluting products overheating.	Reduce time and/or working temperature.
	Polluting products decomposing.	Possibly vacuum distill with the suitable kit.
	Dirt on cover gasket.	Clean cover gasket.
Cover gasket swells.	Cover is opened while recycler is hot.	Open the cover one hour after the cycle is complete.
	The cover gasket is not suitable for the type of solvent to be distilled	Mount the suitable gasket (refer to pages 37 to 39).
Solvent leaks from the gasket.	Worn out gasket.	Replace the gasket.
	Vapor manifold is clogged	Using a funnel, pour in clean solvent, wash vapor tube and blow air into the tube.
	Vapor condenser is clogged.	Replace the condenser.

Symptoms	Possible Causes	Resolutions
Unit is in operation mode but does not heat. Indicator light is ON.	Temperature is set at zero.	Increase temperature.
	Burnt out heater.	Change the defective heater
	Mechanical thermostats is defective.	Change the faulty thermostat.
	Thermocouple sensor is defective	Change the faulty thermocouple
Distills only part of the dirty solvent.	Insufficient operating time selected.	Increase the operating time.
	The undistilled fraction has a boiling temperature higher than the temperature set on the control panel.	Set a higher temperature on the control panel.
	Solvent-boiling temperature is higher than the recycler's maximum working temperature.	Convert to a lower boiling solvent or use a vacuum operated unit.
Trouble light flashes and horn signals a problem	Distillate temperature is over 40°C (104°F).	
	Ventilator motor burns out.	Replace the ventilator motor.
	Vapor condenser internally dirty	Clean by compressed air jet.
	Vapor condenser externally scaled.	Wash it, by pouring clean solvent with a funnel into the manifold
	The security thermostat is defective.	Replace the thermostat
Distillate comes out dirty	Loaded with a quantity superior to the maximum.	Load with the exact quantity.
	Solvent foams.	Wait at least 48 hours before beginning a new cycle
	Temperature set on control panel too high.	Reduce working temperature.
	Vapor manifold or condenser dirty.	Wash it by pouring clean solvent with a funnel into the manifold
Distillate assumes a greenish color.	Distilling solvents or reducers in general.	

Symptoms	Possible Causes	Resolutions
Condenser is becoming corroded.	The solvent is acidic.	Replace copper condenser with a stainless steel condenser.
	Distilling a chlorinated solvent.	
	Temperature set on the control panel is higher than the temperature indicated.	Set the correct working temperature.
	Solvent acidifies. If the temperature set on the control panel is correct, acidification occurred during process before distillation.	Replace the solvent immediately.
Distillation time is more than 4 hours.	There is a considerable percentage of water in the dirty solvent.	Replace the solvent.
	Lack of thermic oil.	Add thermic oil.
	Thermic oil is worn out.	Change thermic oil.
	Heater is scaled.	Remove thermic oil and clean the heater.
Distills only part of the dirty solvent.	Insufficient operating time selected.	Increase the operating time.
	The undistilled fraction has a boiling temperature higher than the temperature set on the control panel.	Set a higher temperature on the control panel.
	Solvent-boiling temperature is higher than the recycler's maximum working temperature.	Convert to a lower boiling solvent or use a vacuum operated unit.
Trouble light flashes and horn signals a problem	Distillate temperature is over 40°C (104°F).	
	Ventilator motor burns out.	Replace the ventilator motor.
	Vapor condenser internally dirty	Clean by compressed air jet.
	Vapor condenser externally scaled.	Wash it, by pouring clean solvent with a funnel into manifold
	The security thermostat is defective.	Replace the thermostat

Symptoms	Possible Causes	Resolutions
No vacuum inside the boiler	Lack of compressed air.	Adjust the air pressure.
	Lack of compressed air circuit.	Check the connection.
	Distilling a chlorinated solvent.	Turn off the distillate-unloading tap.
	The rubber tube of connection to distillate container is not perfectly connected.	Check the connection towards the condenser and connection on rapid clutch.
	Rubber tube deteriorated.	Change the rubber tube.
	Lack of distillate level control.	Check the connections.
	The cover does not have a perfect seal.	Place the cover correctly on the shoulder of the boiler.
	Cover gasket deteriorated.	Replace the gasket.
	Solenoid defected.	Replace the solenoid.
	Vacuum pump damaged.	Change the vacuum pump.
P-OFF Alarm comes on	Lack of compressed air	Check air pressure and refer to INSTALLATION AND STARTING OPERATIONS .
	Vacuum cannot build its pressure	Check vacuum gauge should be between -15 & -25 PSI.
	Faulty Boiler Sensor	Check line from Boiler Sensor on right side and check if any liquid in the tube. Replace when needed.
During the distillation distillate comes out dirty.	Solvent foams.	Use anti-foaming discs, see pages 17 and 40.
		Load less quantity of solvent.
		Reduce the working temperature.
		Reduce the compressed air feeding.
During drying distillate pigments.	Draws polluted products.	Wait at least 48 hours before beginning a new cycle.
		Separate the distillation phase than the drying ones. At the end of the distillation discharge the distillate tank and proceed to dry. At the end of drying wash the tank.
The screen does not come on.	A fuse has blown.	Test the conductivity on all five fuses on the power supply and replace if blown.
	The power supply is broken.	Measure the voltage on all wires from the communication cable between the power supply and the screen. Refer to CONTROL BOARD VOLTAGE MEASUREMENTS in Appendix. If voltage indicates 0V, the power supply is burned and must be replaced.
	The screen is broken.	Measure the voltage on all wires from the communication cable between the power supply and the screen. Refer to CONTROL BOARD VOLTAGE MEASUREMENTS in Appendix. If voltage indicates 4V, the power supply works, but the screen is burned and must be replaced.

MAINTENANCE

Follow these recommendations to ensure proper functioning of your system and avoid costly downtimes and emergency repairs.

We recommend including these routines in your PREVENTATIVE MAINTENANCE program and contact one of our Technical Representatives should you have any questions or concerns.



#	Maintenance Schedule
Every Day	
1	Clean the work surface ①
2	Clean the boiler ②
Every Month	
3	Clean the condenser ③ using a blow gun
4	Check the seal condition ④ and replace as needed
5	Check the oil level ⑤ in the overflow tank with a gauge and make sure it is at minimum 1" or look through the sight view glass inside the cabinet.
Every 2,000 Hours of Operation or Once a Year	
6	Change the cover seal ④ (refer to pages 37 to 39)
7	Change oil ⑤ (see procedure on page 36)
8	Clean the level sensor ⑥

THERMIC OIL CHANGING PROCEDURES

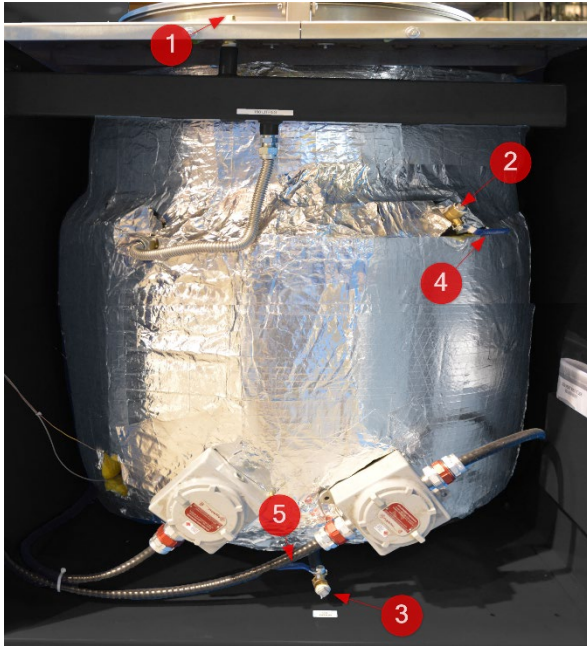

Follow the procedure below to proceed to an oil change. Check oil level frequently to ensure proper distillation performance and to avoid causing damage to the unit.



Oil Draining Procedure

1. Remove Breather Vent plug ① located in front of the cover lid locking lever (units equipped with an optional High-Temperature Kit has the Breather Vent plug located on the left side of the control panel).
2. Remove both plugs ② and ③.
3. Connect a pump inlet hose on the connector where plug ③ was removed and connect the outlet of the pump in a container of at least the oil volume (refer to the name plate for oil volume).
4. Place a rag on the connector where plug ② was removed and open the ball valve ④. Collect excess of oil leaks.
5. Open ball valve ⑤ and activate the pump to drain waste oil from unit. Keep pumping until the unit is completely drained.

Oil Filling Procedure

6. Remove the pump inlet hose and immerse it into a container of brand new Kresco Thermic Oil. Connect the pump outlet hose on the connector where plug ③ was removed.
7. Activate the pump to fill up the unit with brand new oil. Keep pumping until oil start leaking from the plug ② connector. If required, close ball valve ④ and keep filling oil until the unit's oil capacity is achieved. **DO NOT OVERFILL.**
8. Close ball valves ④ and ⑤.
9. Remove the pump inlet hose and put back both plugs ② and ③.
10. Put back the Breather Vent plug ① **MAKING SURE THE BRATHER VENT OUTLET EXHAUST FACES THE COVER LID.**

Refer to the nameplate for the correct oil volume

 Kresco Marquette (Qc) Canada T: (877) 723-3038 E: info@krescosolutions.com	ASSOCIATED EQUIPMENT: CONNECT PER DRAWING 306050-EL	 PS MODEL SERIAL NUMBER YEAR
	CLASS 1, DIVISION 1, GROUP D TEMPERATURE CODE T2A 536 °F (280 °C)	
V Hz Ph kW A	MODEL _____ SERIAL NUMBER _____ YEAR _____	
BOILER CAPACITY _____ LITERS • THERMIC OIL CAPACITY _____ LITERS	CAUTION: to reduce the risk of fire or explosion, install, operate and maintain this equipment in accordance with the instruction manual. This unit has only been investigated for use with the solvent indicated in the instruction manual. ATTENTION : Afin de réduire les risques de feu ou d'explosion, veuillez installer, opérer et entretenir l'équipement conformément avec le manuel d'instruction. Cet équipement a seulement été évalué pour être utilisé avec les solvants indiqués dans le manuel d'instruction.	WARNING : substitution of components may impair intrinsic safety. AVERTISSEMENT : La substitution de composants peut affecter la sécurité intrinsèque de l'appareil.
MADE IN CANADA	(UL 500-WA007-01)	

WARNINGS

Failure to follow the above-mentioned procedures may damage the unit and/or be harmful to operators. In the case that the oil level is too high, the breather vent will exhaust excessive amount of oil. Make sure the breather vent exhaust does not face the operator.

COVER GASKET REPLACEMENT PROCEDURES

Orange Rubber Seal Replacement (Non-Vacuum Assisted Units)

Follow the procedure below to replace the orange gasket on non-vacuum assisted units.

- Step 1.** Remove-cut the old gasket with a cutter or a screwdriver, clean the gasket groove carefully with a rag impregnated with solvent.
- Step 2.** Install the new gasket in place. Using the cardinal points method, push the gasket with your thumb into the groove to distribute the gasket evenly along the groove (Picture 1). Start with the north, south, east, and west points (Picture 2).
- Step 3.** Then repeat the same process to the northeast, southwest, northwest, and southeast points (Picture 3).
- Step 4.** Finally, press the gasket halfway between each of the last two directions (Picture 4).
- Step 5.** Keep pressing in-between sections, making sure the gasket does not form a loop (Picture 5).
- Step 6.** Using your fingers or a round tool, force the gasket sitting completely inside the groove (Picture 6).



Picture 1



Picture 2



Picture 3



Picture 4



Picture 5



Picture 6

Black Braided Seal Replacement (Vacuum Assisted Units)

Follow the procedure below to replace the orange gasket on vacuum assisted units.

- Step 1.** Remove-cut the old gasket with a cutter or a screwdriver, clean the gasket groove carefully with a rag impregnated with solvent.
- Step 2.** The new gasket is pre-cut at 45°. However, it must be adjusted during installation.
- Step 3.** Place the new gasket into the groove all around the cover, starting with one end pre-cut at 45° facing down (Picture 1).
- Step 4.** Using your fingers or a round tool, force the gasket sitting completely inside the groove.
- Step 5.** The two ends of the gasket will overlap slightly. If needed, cut exceeding length at 45° so that it sits perfectly over one another (Picture 2).
- Step 6.** Once in place, the gasket must perfectly cover itself at both ends (Picture 3).

Make a 45° cut on both ends and overlap them with the gasket sitting at the bottom of the groove.



Picture 1



Picture 2



Picture 3

SPARE PARTS LIST

THERMIC OIL



#	Kresco Code	Description
1	OIL-0004	Thermic Oil for Solvent Recyclers (1 Gal / 3.8 L Container)
2	OIL-0010	Thermic Oil for Solvent Recyclers (2.63 Gal / 10 L Container)
3	OIL-0020	Thermic Oil for Solvent Recyclers (5.2 Gal / 20 L Pail)
4	OIL-0205	Thermic Oil for Solvent Recyclers (55 Gal / 205 L Drum)

COVER SEALS



#	Kresco Code	Description
1	GAK-SR180-BLK	SR120/180/240 Black Seal - For Vacuumed Units
2	GAK-SR180-ORA	SR120/180/240 Orange Seal - For Non-Vacuumed Units

PLASTIC SLUDGE BAGS

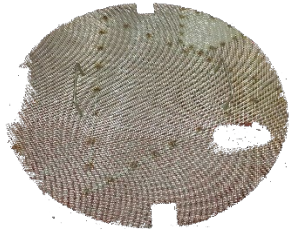

#	Kresco Code	Description
1	BAG-SR240-2-0100	SR240 Plastic Bags 2 mils (Pack 100)
2	BAG-SR240-2-0500	SR240 Plastic Bags 2 mils (Pack 500)
3	BAG-SR240-3-0100	SR240 Plastic Bags 3 mils Heavy-Duty (Pack 100)
4	BAG-SR240-3-0500	SR240 Plastic Bags 3 mils Heavy-Duty (Pack 500)

FOAM BREAKER

#	Kresco Code	Description
1	SROP-SR180-FOAM	SR120/180/240 Anti-Foam Mesh Disc

COMMON REPLACEMENT PARTS



#	Kresco Code	Description
1	CARD-TP-SR	Touch Pad
	CARD-CB-SR	Control Board
2	FIT-V1/4F-90-2V-BR	Ball Valve Brass 1/4" NPTF 90 deg 2-Way
3	FIT-V1/2F-90-2V-BR	Ball Valve Brass 1/2" NPTF 90 deg 2-Way
4	MAN-V-100K-B1/4-PM	Manometer Vacuum 0-100 KPA Behind 1/4" NPT Thread, Panel Mount
5	MAN-P-160P-B1/8-NM	Pressure Gauge 0-160 PSI Back Connection 1/8" NPT
6	REG-1/4AW20	Flow Regulator 1/4" NPT
7	HAR-LATCH-1-7/8X3/4	Door Latch 1-7/8" Long X 3/4" Width
8	LID180-WELD	SRB30/45/60 Welded Cover
	SR18OLID-GAK-ORA	SR120/180/240 Lid and Orange Gasket
	SR18OLID-GAK-BLK	SR120/180/240 Lid and Black Gasket
	BAGRING-SR180	SR120/180/240 Bag Holder Ring
	HAR-RINGLOCK-SR	Ring Bag Latch

SIDE VIEW



#	Kresco Code	Description
1	RAD-CU-SR240	SR240 Copper Radiator
	RAD-SS-SR240	SR240 Stainless Steel Radiator
2	FAN-SR180	SR120/180/240 Fan Blade
3	HUB-5/8	Hex Hub 5/8" with Key Path
4	MOT-1HP-1750-230V/480V-EXP	SR240 230V/480V Motor
	MOT-1HP-1750-600V-EXP	SR240 600V Motor
5	VAL-2/2-1/4-240V-NC-EX	Pilot Valve 240V 2 Way 2 Positions 1/4" NPTF NC Explosion Proof
6	FUS-ATDR-TD-30A-600V	Time Delay Fuse ATDR 30 amp 600V
	FUS-ADTR-TD-25A-600V	Time Delay Fuse ATDR 25 amp 600V
7	SRB-VACGEN-26	Vacuum Generator 26" (Standard)
8	VAL-ROTEX1/2-SA	1/2" Rotex Actuator Valve, Simple Action (NC)
9	VAC-WELD-SR240	SR240 Vacuum Tank
10	PUM-DIAP-1/2-15G	Double Diaphragm Pump 1/2" 15 GPM

SR120/SR180 BOILER HOUSING

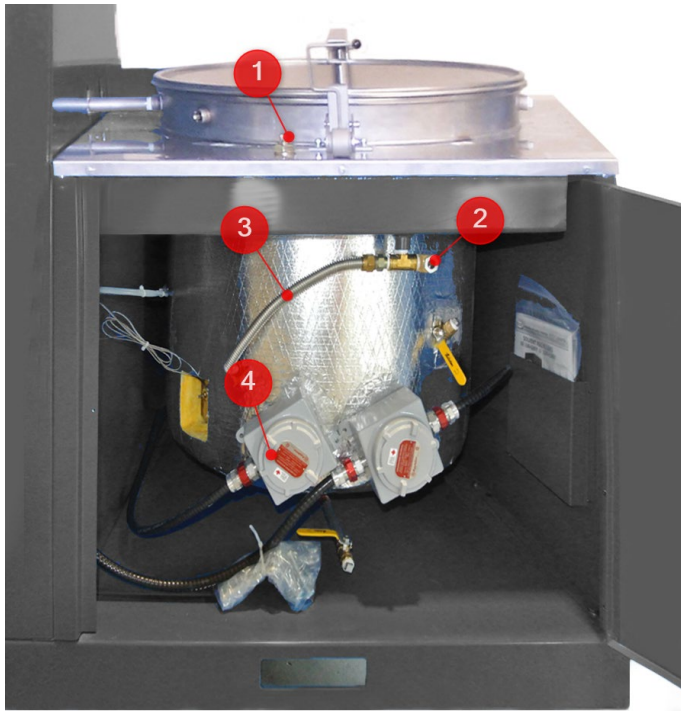

#	Kresco Code	Description
1	FIT-B3/8M-PA	Breather Vent Steel 3/8 NPTM
2	FIT-H1/2M-SS	Oil Level Sight Glass
3	FIT-GP-1/2MX18-SS	Gas Pipe Stainless Steel 1/2" NPTM X 18" Long
4	HEA-6000W-480V	Heating Element 460V 6000W SR240
	HEA-6000W-600V	Heating Element 600V 6000W SR240
5	PROB-K108	Probe Oil Sensor 108"
6	THER-STD	Standard Thermostat

POWER SUPPLIES

Power Supply Kit

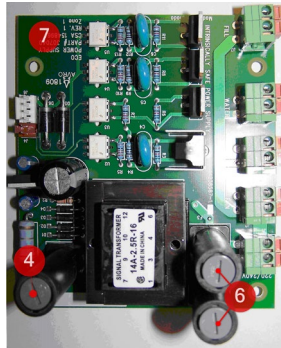
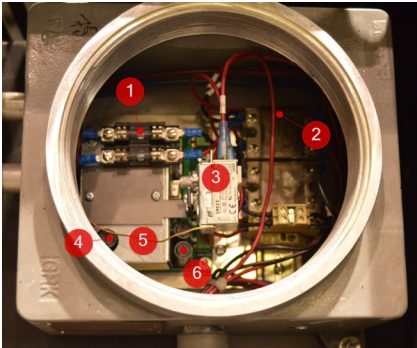

#	Kresco Code	Description
1	FUS-AGC-FA-1/2A-250V	Fast Action Fuse AGC 1/2 Amp 250V
2	REL-SSR-230V-25A-CARLO	Relay 23 amp 200-240 volts
3	THER-STD	Standard Thermostat
4	FUS-MDQ-TD-1/4A-250V	Time delay fuse MDQ 1/4 Amp 250V
5	SRB-INTR	Intrinsic Barrier
6	FUS-MDQ-TD-1/16A-250V	Time Delay Fuse MDQ 1/16 Amp 250V
7	PSUP-PS-SR	SR Power Supply Board

Power Supply to Explosion-Proof Box

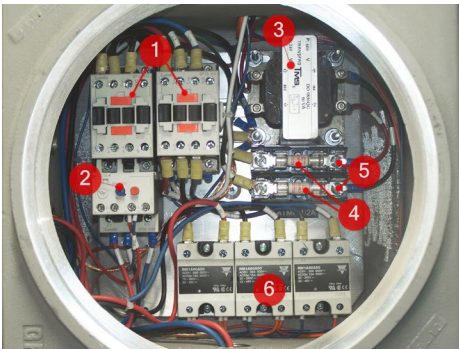

#	Kresco Code	Description
1	CONT-7.5HP-240V	Contacter 7.5 HP 240 Volt Coil
2	REL-1.6-2.5A	Overload Relay 3 Phases 10A 600V
3	TRAN-SB600/240-50VA	Transformer Split Coil 600-240V 50VA
4	FUS-ATMR-FA-1/2A-600V	Fast Acting Fuse ATMR 1/2 amp 600V
5	EPA-FUH-30A-600V	Fuse Holder 30A 600V
6	REL-SSR600V-75A	Solid State Relay 75A 600V AC

OPTIONAL FEATURES

Sludge Bag Handling Device



#	Kresco Code	Description
1	SROP-CRANE	Bag Lifting Crane System
2	SROP-SR240-BASKET	Residues Basket for SR240
3	HAR-RCLAMP	Wire Rope Clamp for 1/4" Rope Diameter (Sold by ft)
4	PUL-VMT2X1/2	Pulley V-Monted 2" OD x 1/2" Bore
5	COCAB-3/16ORA-GA	Galvanized Steel Coated Cable 3/16" Orange
6	HAR-TREUIL-SR	Winch for Lifting Arm
7	HAR-TABLESR	Lifting Arm Heavy-Duty Turn Table (1,500 lbs)

Auto-Fill System

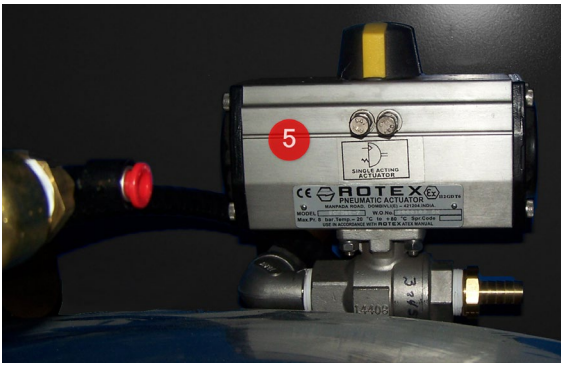
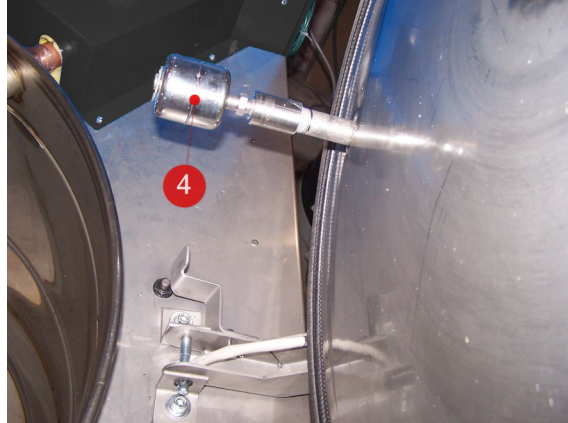
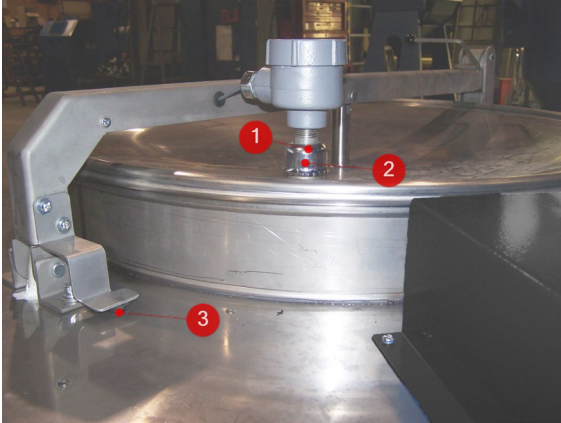

#	Kresco Code	Description
1	GAK-OR13/16-HTS	O-Ring High-Temperature Silicon 13/16" Seat (Orange)
	GAK-OR3/16-VITON	O-Ring Viton 3/16" Seat (Black)
2	COU-DC-1/2X3-1/2	Dresser Coupling 1/2" X 3-1/2"
3	VAL-3/2-1/4-MEC-NC-SP	Pilot Valve Mechanic 3 Outputs 2 Positions 1/4" NPT Thread NC Straight Plunger
4	LVL-120V-VER-SS	Vertical Liquid Level Switch 120V SS316
5	VAL-ROTEX1/2-SA	1/2" Rotex Actuator Valve, Simple Action (NC)

External Light Box



#	Kresco Code	Description
1	LIG-BULB-12V-AMB	Amber Light
2	LIG-BULB-12V-RED	Red Light
3	LIG-BULB-12V-GRE	Green Light

Sludge Monitoring Safety Device

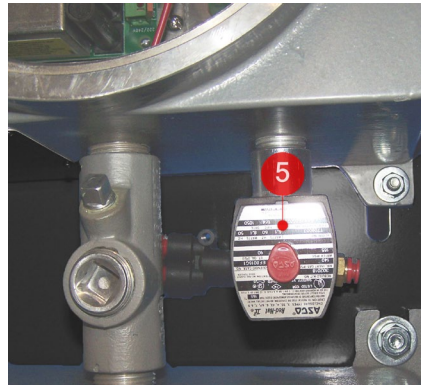
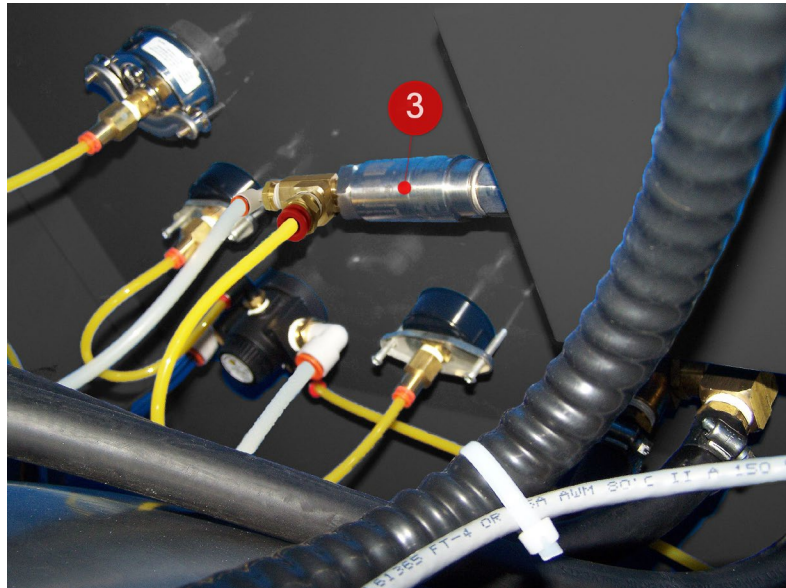
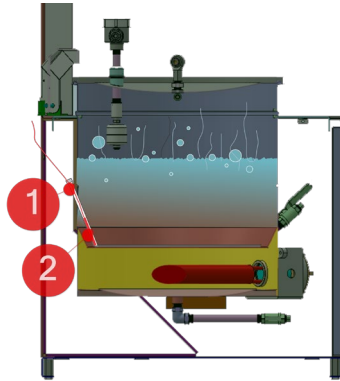

#	Kresco Code	Description
1	FIT-C3/8NITRO	Connector Comp. Brass 3/8" Comp. X 3/8" NPTM
2	PROB-K120-6	Sludge Temperature Thermocouple
3	PS-25-65PSI-1/2-SS	Pressure Switch 25-65 PSI 1/2" NPTM SS316
4	MAN-P-160P-B1/8-NM	Pressure Gauge 0-160 PSI Back Connection 1/8" NPT
5	VAL-2/2-1/2-240V-NC-EX	Pilot Valve 240V 2 Way 2 Positions 1/2" NPTF NC Explosion Proof

OPTIONAL EXTERNAL LIGHT BOX

TAG REC	TAG REC	QTY	PART No	DESCRIPTION	MANUFACTURER
H1.1	L11	1	MPO01/RD	PILOT LIGHT LED SWDC	BILSON
H1.2	L12	1	MPO01/AM	PILOT LIGHT LED SWDC	BILSON
H1.3	L13	1	MPO01/GR	PILOT LIGHT LED SWDC	BILSON
EB1	EB1	1	DUK0884	ELECTRICAL BOX	BEL
CBL1.1	CBL1.1	1	548240765TF14	MULTI-CONDUCTOR FOIL & BOND	ELECTRO CABLES

DESIGNED BY:	ERIC	DATE:	2023-05-18
DRAWN BY:	ERIC	DWG NO.:	SR-ELECT-CSA-UL
ISSUE PAR:	ERIC	SCALE:	—
CHECKED BY:	VERIFIE PAR:	REVISION:	9
		PAGE:	1 OF 1

OPTION LIGHT BOX BEL DUKO/DKO DUK0884

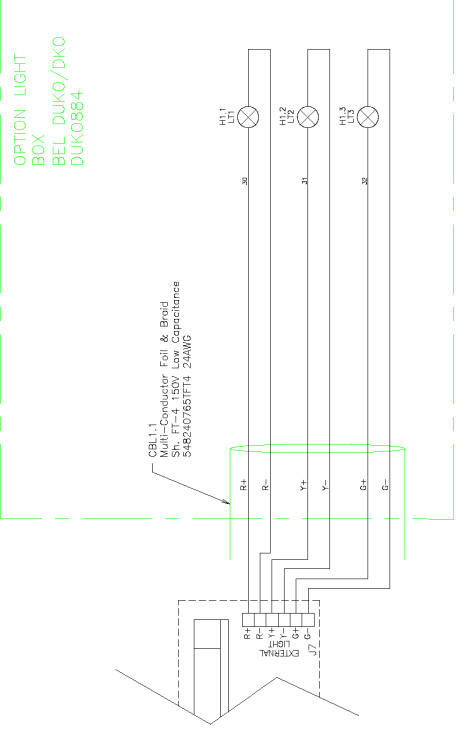

TOLERANCE DE FABRICATIONS TOLERIE/SOUDURE FRACTIONS: +1/16" DECIMAL: XX .40/15 PLAGE/BENDING: +1"	MACHINAGE FRACTIONS: +1/32" DECIMAL: XX .40/15 DECIMAL: XXX .40/15
--	--

EXCLUSIVE RIGHTS

THIS DRAWING IS THE EXCLUSIVE PROPERTY OF IST SURFACE INC. NO PART OF THIS DRAWING IS TO BE REPRODUCED OR TRANSMITTED IN ANY FORM OR BY ANY MEANS, ELECTRONIC OR MECHANICAL, INCLUDING PHOTOCOPYING, RECORDING, OR BY ANY INFORMATION STORAGE AND RETRIEVAL SYSTEM, WITHOUT THE WRITTEN PERMISSION OF IST SURFACE INC. POSSESSION OF THIS DRAWING DOES NOT AUTHORIZE USE NOR TRANSMISSION TO ANY OTHER ORGANIZATION.

DROITS D'AUTEUR

CE DESSIN EST LA PROPRIETE DE IST SURFACE INC. LES INFORMATIONS CONTENUES DANS CE DESSIN NE PEUVENT ETRE REPRODUITES NI TRANSMISEES EN AUCUNE MANIERE, ELECTRONIQUE OU MECANIQUE, Y COMPRIS LA PHOTOCOPIE, L'ENREGISTREMENT, OU PAR N'IMPORTE QUEL SYSTEME DE STOCKAGE ET DE RECUPERATION D'INFORMATIONS, SANS LA PERMISSEION ECRITE D'IST SURFACE INC. LA POSSESSION DE CE DESSIN N'AUTORISE NI L'UTILISATION NI LA TRANSMISSION A QUICONQUE DES INFORMATIONS QU'IL CONTIENT.

CONTROL BOARD VOLTAGE MEASUREMENTS

Put one probe on the red cable and the other probe on all other cables, one by one, to take the voltage readings. If you are reading a negative value, reverse the two probes.

Communication cable wires standard voltage readings are the ones indicated in the scheme below. If any of these readings indicate 0, the power supply is burned and must be replaced.

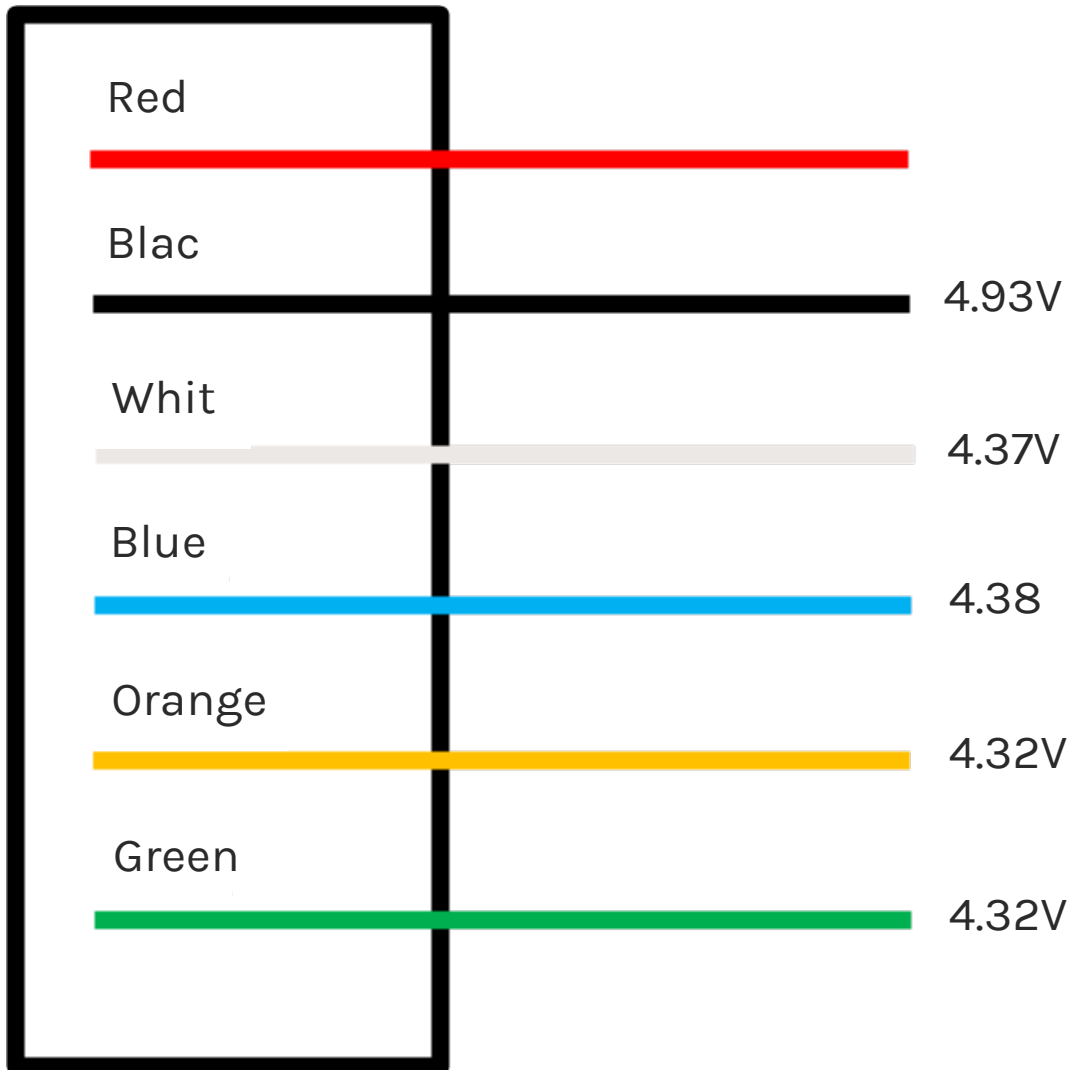

→

WARRANTY STATEMENT

Kresco warrants all equipment led in this manual which is manufactured by **Kresco** and bearing its name, to be free from defects in material and workmanship on the date of sale by an authorized **Kresco** distributor to the original purchaser for use. Notwithstanding any special, extended or limited warranty published by **Kresco** will, for a period of TWELVE (12) months from the date of sale, repair or replace any part of the equipment determined by **Kresco** to be defective.

This warranty applies only when the equipment is installed, operated and maintained in accordance with **Kresco's** written recommendations. This warranty DOES NOT cover, and **Kresco** shall not be liable for general wear and tear, or any malfunction, damage or wear caused by faulty installation, misapplication, abrasion, corrosion, inadequate or improper maintenance, negligence, accident, tampering, or substitution of non-**Kresco** component parts. Nor shall **Kresco** be liable for malfunction, damage or wear caused by the incompatibility with **Kresco** equipment with structures, accessories, equipment or materials not supplied by **Kresco**, or the improper design, manufacture, installation, operation or maintenance of structures, accessories, equipment or materials not supplied by **Kresco**.

This warranty is conditioned upon the prepaid return of the equipment claimed to be defective to an authorized **Kresco** distributor for verification of the claimed defect. If the claimed defect is verified, **Kresco** will repair or replace free of charge any defective parts. The equipment will be returned to the original purchaser, transportation prepaid. If the inspection of the equipment does not disclose any defect in material or workmanship, repairs will be made at a reasonable charge, which charges may include the costs of parts, labor, and transportation.

THIS WARRANTY IS EXCLUSIVE, AND IS IN LIEU OF ANY OTHER WARRANTIES, EXPRESSED OR IMPLIED, INCLUDING BUT NOT LIMITED TO WARRANTY OF MERCHANTABILITY OR WARRANTY OF FITNESS FOR A PARTICULAR PURPOSE.

Kresco's sole obligation and the buyer's sole remedy for any breach of warranty shall be as set forth above.

The buyer agrees that no other remedy (including, but not limited to, incidental or consequential damages for lost profits, lost sales, injury to person or property, or any other incidental or consequential loss) shall be available. Any action for breach of warranty must be brought forward within two (2) years of the date of sale.

Kresco MAKES NO WARRANTY, AND DISCLAIMS ALL IMPLIED WARRANTIES OF MERCHANTABILITY AND FITNESS FOR A PARTICULAR PURPOSE, IN CONNECTION WITH ACCESSORIES, EQUIPMENT, MATERIALS OR COMPONENTS SOLD BUT NOT MANUFACTURED BY **Kresco**. These items sold, but not manufactured by **Kresco** (such as electric motors, switches, hose, etc.), are subject to the warranty, if any, of their manufacturer. **Kresco** will provide the purchaser with reasonable assistance in making any claim for breach of these warranties.

LIMITATION OF LIABILITY

In no event will **Kresco** be liable for indirect, incidental, special or consequential damages resulting from **Kresco** supplying equipment hereunder, or the furnishing, performance, or use of any products or other goods sold hereto, whether due to a breach of contract, breach of warranty, the negligence of **Kresco**, or otherwise.

Report all accidents or "near misses" which involve **Kresco** products to:

- Kresco Technical Assistance at 1-877-757-3726

The following items are not covered under the **Kresco** warranty policy:

- Parts or chassis replacement due to normal wear
- Consumables and replacement parts (bags, sealing gaskets, thermic oil, etc.)

Defective material or workmanship is not considered normal wear

ABOUT KRESCO

Kresco designs, manufactures, and supports industrial equipment for the surface treatment industries. **Kresco** has standard equipment designed for most applications and can customize equipment to meet or exceed your production expectations.

SANDBLASTING

- Sandblast Booths
- Sandblast Cabinets
- Automated Sandblasting Systems
- Abrasive Reclaiming Systems
- Pressurized Sandblasters
- Dust Collectors

SHOT BLASTING

- Roller Conveyor Blaster
- Rotary Table Blaster/Swing Table Blaster
- Spinner Hanger (Batch)
- Continuous Flow with Monorail.
- Rubber and Steel Flight Tumbler Blasters
- Flow Thru Barrel Blasters
- Mesh Belt Continuous Blasters
- Monorail System Blasters
- Rim Blasters
- Preservation Line

PAINTING & COATING

- Paint Spray Booths
- Powder Coating Booths
- Drying Ovens

SOLVENT RECOVERY

- Batch Solvent Distillers
- Continuous Flow Solvent Distillers
- Oil Cooling Systems

PARTS & CONSUMABLES

- Blast Nozzles
- Blast Hoses
- Abrasive Media (Glass Bead, Aluminum Oxide, Steel Shot and Grit)
- Air Valves
- Abrasive Metering Valves
- Cartridge Filters
- Sludge Bags
- Safety Equipment & PPE

SERVICES

- Turnkey Project Design
- Custom Design
- Full Installation
- Start-up Supervision
- Training
- Maintenance
- Retrofit & Upgrade

All systems are designed to build and they are manufactured with the highest quality standards in our manufacturing shop in Quebec, Canada.