

# **Sandblast Pot – Single Operator**

## **Model SBP-1050DC-125P**

### **Instruction manual**



*Revision: December 19, 2025*

---

**Kresco**

Address: 1404, avenue de la Gare, Mascouche, QC J7K 2Z2

Telephone: (877) 757-3726 • Email: [info@krescosolutions.com](mailto:info@krescosolutions.com) • Website: [krescosolutions.com](http://krescosolutions.com)

# TABLE OF CONTENTS

WARNING .....	4
GENERAL SAFETY RULES.....	5
EQUIPMENT OVERVIEW.....	6
1. DEBRIS DRAWER.....	7
2. PLUNGER VALVE .....	7
3. PRESSURE MANOMETER.....	7
4. COMBO VALVE.....	8
5. DEPRESSURIZATION HOOSE .....	9
6. BALL VALVE (AIR INLET).....	9
7. AV-186 AIR VALVE.....	10
8. AIR-POWERED SOLENOID VALVE 5 PORT.....	10
9. UNION BALL VALVE (MEDIA FLOW CUT-OFF).....	10
10. MEDIA REGULATION VALVE.....	10
11. SANDBLASTING HOOSE CONNECTION .....	11
12. AIR INTAKE MANIFOLD .....	11
PREPARING THE SANDBLASTER.....	13
INSPECT THE PRESSURE VESSEL.....	13
TIGHTEN THE MAINTENANCE ACCESS DOOR.....	13
AIR HOSH PURGE .....	13
INSTALL THE REMOTE-CONTROL HANDLE.....	13
BEFORE STARTING SANDBLASTING.....	14
PRELIMINARY CHECK.....	14
ADDITION OF ABRASIVE .....	14
REMOTE-CONTROL HANDLE .....	15
CONNECT THE HOSES .....	16
OPERATING PRINCIPLE.....	16
ADJUSTING THE MEDIA REGULATION VALVE .....	18
ADJUSTING THE MEDIA REGULATION VALVE .....	19
SANDBLASTER OPERATION .....	20
SANDBLASTER PRESSURIZATION .....	20
BEFORE STARTING SANDBLASTING OPERATIONS.....	21
HOW TO OPERATE THE SANDBLASTER.....	21



STOP THE SANDBLASTER .....	21
AIR HOSE DISCONNECT .....	23
PREVENTIVE MAINTENANCE.....	24
SANDBLASTER .....	24
SANDBLASTING EQUIPMENT .....	26
SPARE PARTS LIST.....	27
SANDBLASTING HOSES, FITTINGS AND NOZZLES .....	27
REMOTE-CONTROL HANDLE .....	33
1-1/4" COMBO VALVE.....	35
AV-186 AIR VALVE.....	37
MEDIA REGULATION VALVE .....	39
TROUBLESHOOTING.....	42
WARRANTY STATEMENT.....	46
LIMITATION OF LIABILITY.....	46
ABOUT KRESCO .....	47

## WARNING

1. All persons who will use or be in the vicinity of the sandblaster during its operation must receive proper training on how to safely operate the equipment and be informed of potential hazards. In addition to the training itself, all persons who will use or be in the vicinity of the sandblaster during its operation must read, understand, and follow all procedures described in the operator's manual. For replacement manuals, please contact your distributor or visit [krescosolutions.com](http://krescosolutions.com).
2. Respiratory protection is mandatory for all persons using or being in the vicinity of the sandblaster. Follow all applicable safety requirements in your jurisdiction for supplied-air respirators.
3. Pressure vessels contain large amounts of stored energy and can cause serious injury or death if safety procedures are not followed. Never perform maintenance on or attempt to open a pressure vessel for any reason while it is pressurized. Always properly depressurize and disconnect equipment from its air source before performing any maintenance. Do not modify, grind, or weld on the pressure vessel for any reason. Doing so will void the ASME certification. Do not use damaged pressure vessels.
4. The use of appropriate remote-control systems (commonly known as Deadman controls) is necessary when operating sandblasting equipment. Never operate the sandblaster without a remote-control.
5. All persons using or being in the vicinity of the sandblaster during its operation must protect themselves with appropriate safety equipment and use common sense. Safety equipment, including but not limited to hearing, eye, body, and lung protection, is required. The pressure vessel and the objects being sandblasted can be heavy and cause serious injury or death if they tip over. Always comply with the safety requirements in force in your jurisdiction.
6. Use only genuine Kresco replacement parts when servicing the sandblaster. Do not modify the equipment for any reason. Using other brand parts may cause a dangerous situation and will void your warranty.
7. Never use damaged or malfunctioning equipment. Before each use, inspect the sandblaster for proper operation.
8. Supply only fresh, dry air, free of contaminants, to your sandblaster. Moisture or debris reaching the remote-control system can create a hazardous situation. Do not supply compressed air exceeding 150 psi to the pressure vessel.
9. The use of an air pressure regulator is highly recommended.
10. Do not use the sandblaster in any location that could be considered a hazardous location as described in NFPA National Electrical Code 70, Section 500. Never use the sandblaster in humid environments. Always connect an electrically operated sandblaster to a ground fault circuit interrupter (GFCI).

## GENERAL SAFETY RULES

### DANGER AND WARNING LABELS

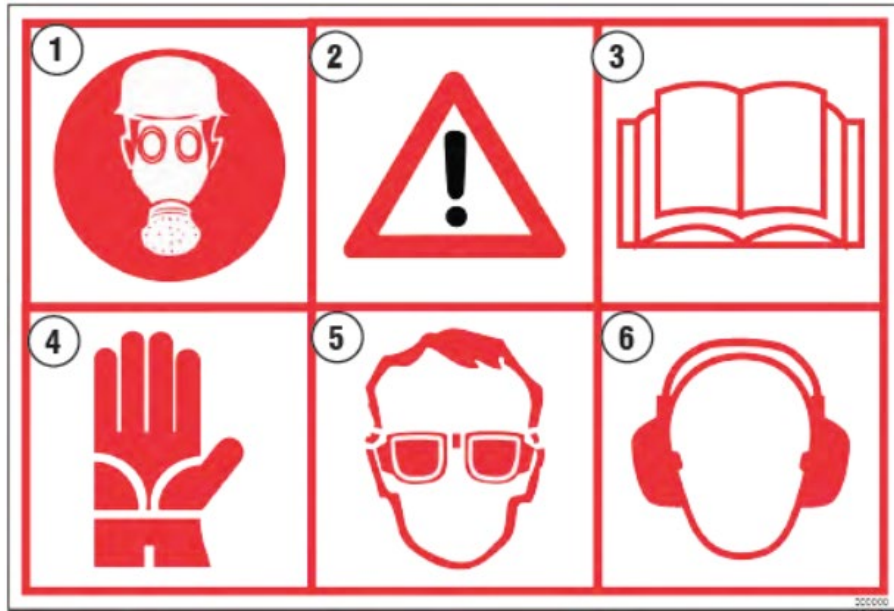

1. Wear a respiratory mask
2. Heed the warnings at all times
3. Read the instruction manual carefully
4. Wear safety gloves before use
5. Wear safety glasses before use
6. Wear hearing protection before use

### WARNINGS

Please read the user manual and all other safety instructions carefully before using this equipment. Failure to follow the SAFETY RULES and other precautions described in this document may result in serious injury.

### WARNINGS

Sandblasting systems can emit potentially hazardous dust and airborne contaminants during operation. Appropriate respiratory protection must be worn at all times when operating or near the equipment.

## EQUIPMENT OVERVIEW

Here is a brief description of the main components of the sandblaster and their function.

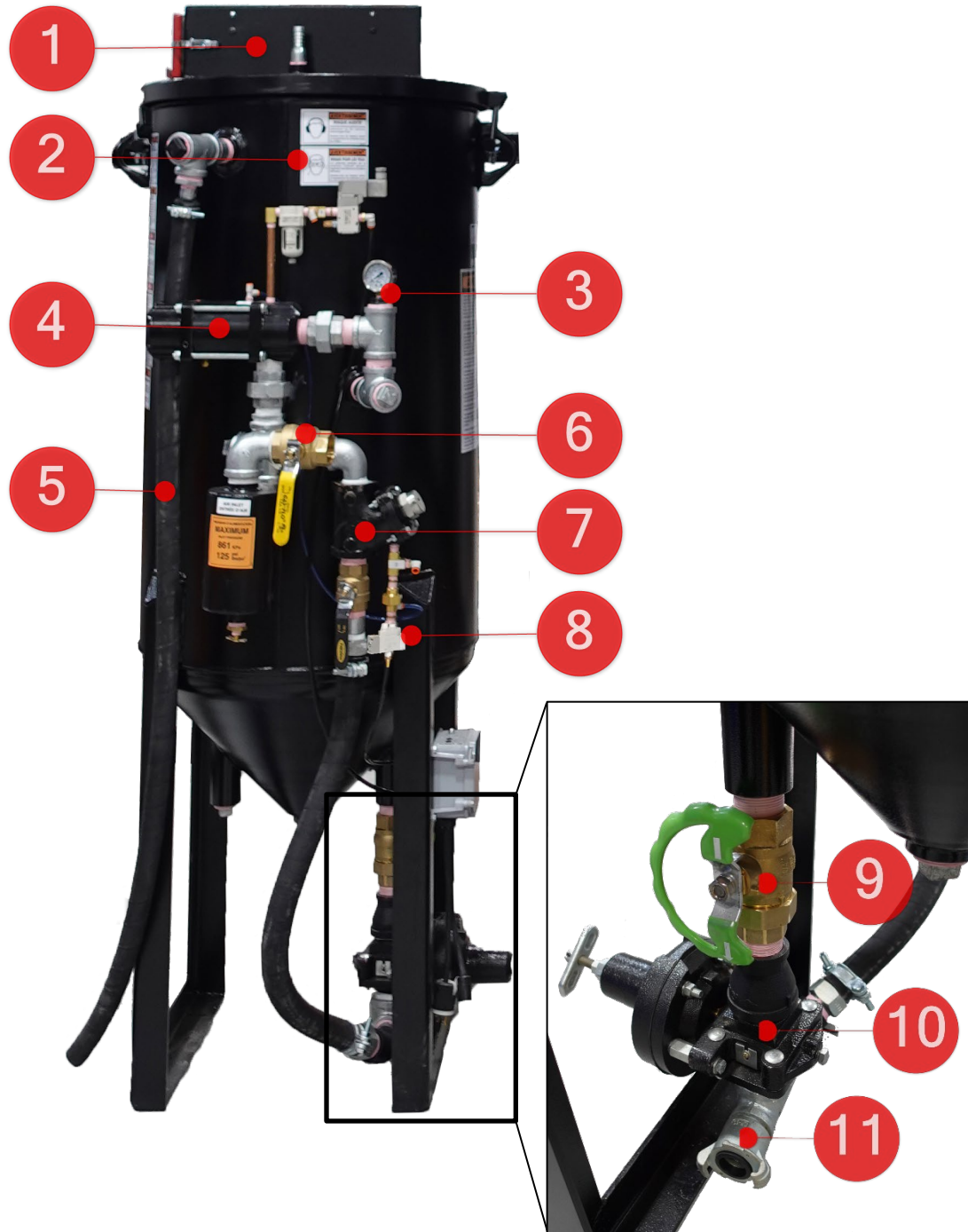

## 1. DEBRIS DRAWER

The debris trap drawer captures the debris collected by the recovery system so they can be disposed of before it reaches the sandblasting pot's plumbing and risks damaging critical components such as valves.



## 2. PLUNGER VALVE

The plunger valve (commonly called 'Pop-Up Valve') covers the upper opening of the vessel seal in order to pressurize the sandblaster.



### SANDBLASTER PRESSURIZATION

When air is introduced into the sandblaster and its exhaust is blocked, the plunger valve rises and sits on a urethane seal to seal the vessel and allow it to build up pressure.

At the same time, this action helps to block access to the abrasive media.

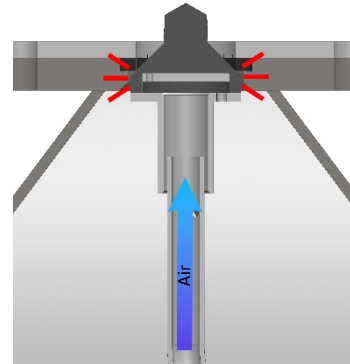

### SANDBLASTER DEPRESSURIZATION

Conversely, when the air supply is suspended and the sandblaster's exhaust is opened, the sandblaster depressurizes and the plunger valve falls back down, allowing the abrasive media to flow inside the sandblaster.

This operation is necessary to fill the sandblaster with material.

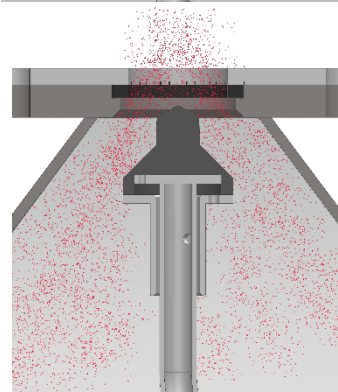

## 3. PRESSURE MANOMETER

The pressure gauge allows you to see the air pressure of the sandblaster. This pressure is the same inside the sandblaster as in the sandblasting hose (therefore, the working pressure at the sandblasting nozzle).



## 4. COMBO VALVE

The combo valve control enables the airflow into and out of the pressurized vessel the pressurization and depressurization operations of the sandblasting vessel directed in order to control the pressurization and depressurization operations of the sandblasting vessel.



Its principle is based on two air passages at each end of the valve as well as a pinch tube that moves from left to right in order to leave only one passage at a time.

The left passage is for the exhaust hose of the pressure vessel, while the right one is for the air inlet which supplies both the sandblaster and the sandblasting hose.

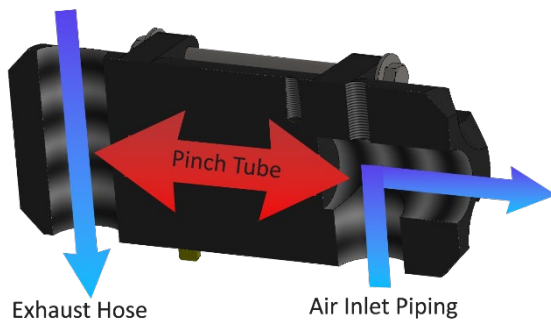

This valve is controlled by a solenoid valve. The control method varies depending on the unit configuration. Blast booths equipped with a remote-control switch box can control this valve using the 'Pressurization/Depressurization' switch inside the booth. Otherwise, this valve is manually activated using ball valves installed on the sandblaster.

### SANDBLASTER PRESSURIZATION

When the pinch tube moves to the left of the valve, it pinches the sandblaster's exhaust hose while simultaneously opening the air intake. The sandblaster can then pressurize.

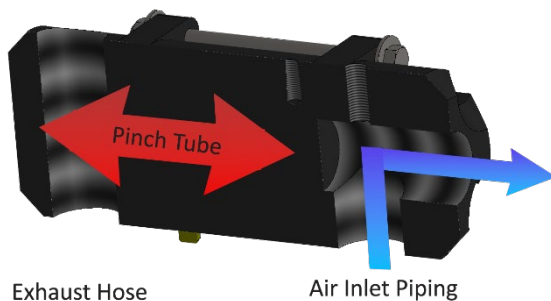

## SANDBLASTER DEPRESSURIZATION

Conversely, when the tube moves to the right of the valve, it obstructs the air intake of the sandblaster while allowing the exhaust hose to return to its normal shape, enabling the pressurized vessel to vent out its air. The sandblaster can then depressurize.

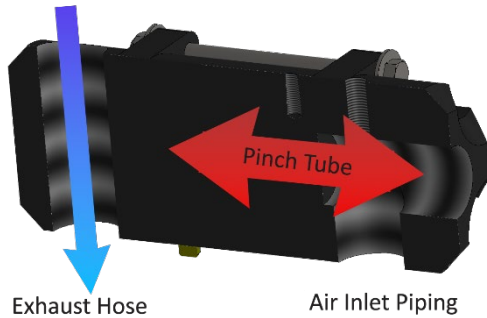

## 5. DEPRESSURIZATION HOOSE

The depressurization hose allows air to be evacuated from inside the sandblaster. This can be controlled manually (using a ball valve at the sandblaster's exhaust outlet) or automatically via the combo valve (which pinches or releases the exhaust hose, depending on the desired action).

## 6. BALL VALVE (AIR INLET)

The ball valve located at the air inlet of the sandblaster allows the sandblaster to be connected to a compressed air line in order to supply the unit with air during normal operations.

It is strongly recommended to install a pressure regulator (not supplied) with a pressure gauge at the air inlet of the sandblaster in order to control the internal pressure of the sandblaster as well as the working pressure at the nozzle.



Ball Valve



Pressure regulator

## 7. AV-186 AIR VALVE

The AV-186 air valve controls the compressed air supply to the blast line (sandblasting hose). It is a diaphragm valve controlled by a solenoid valve.

This valve activates (allows air to pass through) when all the doors of the sandblast booth are closed (no alarm is active) and the operator presses the remote-control handle. It closes if either of the two conditions mentioned above is not met.



## 8. AIR-POWERED SOLENOID VALVE 5 PORT

The solenoid valve activates/deactivates the AV-186 air valve and the combo valve. This valve is controlled from the remote-control handle (as well as the optional door safety switches).



A pneumatic signal is sent to both the AV-186 air valve and the combo valve when the operator presses the remote-control handle and all booth doors are closed (if the doors are equipped with safety switches).

## 9. UNION BALL VALVE (MEDIA FLOW CUT-OFF)

The union ball valve allows the abrasive supply to be cut off for maintenance purposes only on the media regulating valve.

This valve should normally remain open and not be handled unnecessarily, at the risk of damaging it.



## 10. MEDIA REGULATION VALVE

The flow control valve allows control of the volume of abrasive media that is injected, by gravity alone, into the blast hose. The abrasive flows through a tungsten sleeve and mixes with the flow of compressed air, which propels it at high velocity through the blasting nozzle.

Its operating principle is simple. It consists of a valve normally closed by a spring. In the closed position, a tungsten plunger pinches the tungsten sleeve, blocking the passage of the abrasive.

Once activated by an air pilot, the tungsten plunger retracts, opening the passage for the abrasive. The passage opening can be controlled using an adjustment knob. Follow the MEDIA REGULATION VALVE ADJUSTMENT procedure to achieve the optimal setting for your application.



## 11. SANDBLASTING HOOSE CONNECTION

The blast hose connects to the system by means of a quick-disconnect (Chicago) fitting located at the outlet of the media control valve.

We strongly recommend the use of safety clips on each hose section to protect operators and employees in case of accidental disconnection.



## 12. AIR INTAKE MANIFOLD

The customer is responsible for supplying compressed air to the system following the instructions of Kresco representatives.

### WARNINGS

**SUPPLY ONLY CLEAN, DRY AIR** to the sandblast pot.

Moisture, oil, and other airborne impurities present in the compressed air supply can contaminate the abrasive, preventing it from flowing freely, causing ineffective sandblasting actions, and leading to premature wear of plumbing and critical components.

If necessary, install an air dryer and/or an inline air filtration system to remove any moisture or contaminants present in the air.

### WARNINGS

Connect the air intake manifold **USING ONLY A STRAIGHT AND AIRTIGHT FITTING.**

Never use male-female quick couplings or other types of couplings that may cause air leaks and impair sandblasting performance.

The air supply to the sandblaster and its auxiliary equipment is taken from an air inlet manifold located near the sandblaster.

1. 1-1/2" system air inlet (from the compressor)
2. 3/8" air outlet for supplying the sandblasting chamber dust collector
3. 3/8" air outlet for supplying the PARS2000 dust collector's pulsation system
4. 1-1/2" outlet for sandblaster supply
5. 3/8" outlet for supplying the respiratory protection system (sandblasting helmets and hoods with filtered air supply)
6. 1-1/2" outlet for sandblaster supply (optional)

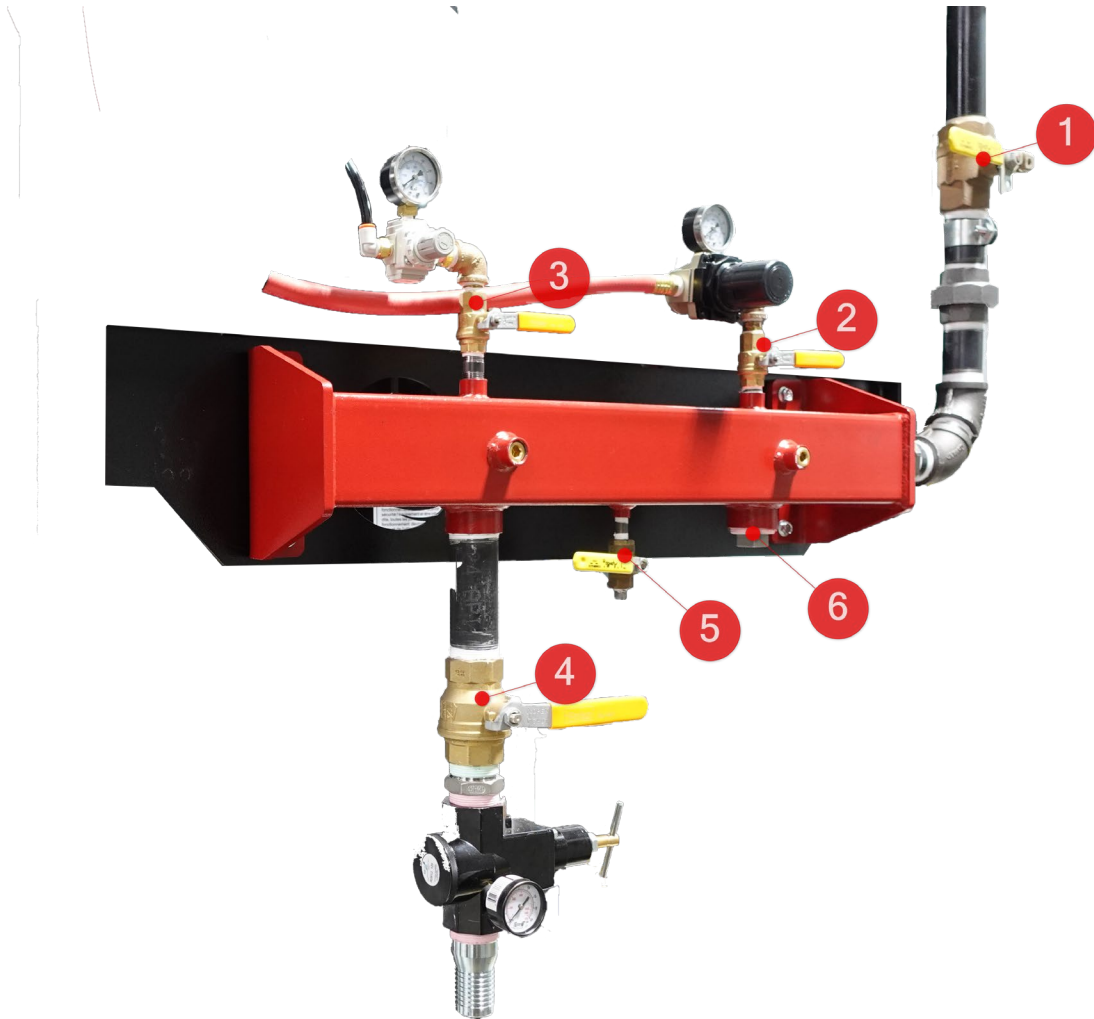

## PREPARING THE SANDBLASTER

### WARNINGS

The procedures outlined in the "Operating Procedures" section of this manual are designed to provide basic information on how to safely operate Kresco sandblasters. Only personnel properly trained in the use of the equipment should operate the sandblaster.

### !HAZARD!

Never perform any maintenance or attempt to open the sandblaster under any circumstances while it is pressurized. The violent release of compressed air and propelled objects can cause serious injury or death.

### INSPECT THE PRESSURE VESSEL

When you receive your sandblaster, remove the inspection door and check for any foreign objects that may have fallen into the sandblaster through the filling opening. Remove any foreign material and reinstall the maintenance access door.

### TIGHTEN THE MAINTENANCE ACCESS DOOR

After the sandblaster has been pressurized for the first time, tighten the inspection door nut. The inspection door nut must also be tightened each time the inspection door has been removed for maintenance, both before and after pressurization.

### AIR HOSE PURGE

Before connecting the air supply hose to the sandblaster, purge the hose of any moisture or foreign debris. The presence of water or moisture in the air line will degrade the sandblaster's performance. The air supplied to the sandblaster must be clean, dry, and exempt of oil and other contaminants.

### INSTALL THE REMOTE-CONTROL HANDLE

Attach the remote-control handle to the sandblasting hose near the nozzle with cable ties or nylon wire ties.

Next, form a loop with the double air hose where the first 6 inches away from the sandblasting hose, then at the next 6 inches parallel to the sandblasting hose, then a final 6-inch curve to link with the sandblasting hose.

At the point where the loop ends, attach the twin air hose to the blasting hose by wrapping tape twice around the twin air hose, then around the blasting hose to form a strain relief tie. Do this only the first time you connect it near the control handle.

Secure the remainder of the twin air hose to the sandblasting hose by wrapping tape around the twin air hose and the sandblasting hose every 3 feet, starting at the nozzle end of the sandblasting hose.

## **BEFORE STARTING SANDBLASTING**

### **PRELIMINARY CHECK**

Before each use, the sandblaster must be inspected to ensure it is in good working condition. Carefully examine all components of the sandblaster for signs of excessive wear: worn seals and hoses, damaged parts. If any component of the sandblaster is found to be damaged or worn, it must be replaced before using the sandblaster.

### **WARNINGS**

Never use a sandblaster if any components are damaged or worn. Damaged or worn parts must be replaced before use.

### **ADDITION OF ABRASIVE**

Before filling the sandblaster, ensure the inlet valve is closed and the pressure tank is depressurized. Pour the abrasive into the top of the sandblaster. Allow the abrasive to flow around the plunger and into the pressure tank. Be careful not to overfill or allow foreign objects to enter. To prevent foreign objects from entering, the use of a screen is recommended.

### **!HAZARD!**

Never put your hands in the filling opening when pouring abrasive into the sandblaster. The plunger can close unexpectedly and cause serious injury or death.

## WARNINGS

Never use abrasive products that contains silica.

The inlet valve must NEVER be open while filling the sandblaster. Always close it before starting to fill.

NEVER use electrically conductive abrasives when the sandblaster is used with electric remote-control systems unless the sealed strain relief connectors have been replaced.

A sandblaster containing abrasive should NEVER be moved or transported.

## REMOTE-CONTROL HANDLE

An electric or pneumatic remote-control system (also called a "deadman") must always be used with a sandblaster to start and stop sandblasting.

### ELECTRIC

The remote-control handle must be connected to the sandblaster's twist-lock female connector. A 12 VDC power source (12 V battery or optional 120 VAC to 12 VDC converter) must be connected to the twist-lock male connector.

### PNEUMATIC

The remote-control's dual pneumatic hose must be connected to the sandblaster using the threaded or quick-disconnect fittings provided. Pneumatic remote-control systems are only suitable for hoses up to 115 feet long. For hoses longer than this, an electrically controlled system is required.

## WARNINGS

Never operate the sandblaster without a remote-control system.

## !HAZARD!

Always be careful around electrical sources to avoid electric shock. Do not operate electrical remote controls in humid or other hazardous environments.

## CONNECT THE HOSES

Before connecting the hoses to the sandblaster, ensure the air intake valve is closed and the compressed air supply is shut off. Connect the hose from the compressed air supply to the inlet on the sandblaster and secure it with the safety clips. The use of an air pressure regulator is strongly recommended.

Connect the sandblasting hose coupling to the metering valve at the base of the sandblaster and secure it with the safety fasteners.

### WARNINGS

Safety devices, such as clips and whips (safety cables), should always be used to secure the hose.

## OPERATING PRINCIPLE

When the 'Pressurization/Depressurization' switch is set to 'pressurization', the AV-176 combo air valve opens to allow air to enter and pressurize the tank. The pressurized tank is now ready for the sandblasting operation.

Before the sandblasting operation can begin, all doors to the blast booth, equipped with a safety switch, must be closed. Only when all doors are closed will the operator be able to start the sandblasting operation.

The operator starts the sandblasting operation by pressing the control handle located on the sandblast hose near the nozzle. The engaged handle simultaneously signals the combo valve and the AR8 abrasive metering valve to open and begin the sandblasting operation.

When the operator releases the control handle, the sandblasting operation stops. The pressure vessel remains pressurized, ready to resume the sandblasting operation when the operator presses the control handle again.

When the sandblasting process is complete or when the pressure vessel needs to be refilled with abrasive, the operator releases the control handle and sets the 'Pressurization/Depressurization' switch to 'depressurized'. Once depressurized, the plunger inside the sandblaster drops back down, and the abrasive media stored above the sandblaster can then flow into the sandblaster to refill it.

The 'sandblasting/air only' switch allows the AR8 abrasive metering valve to be closed while maintaining a supply of compressed air to the blast line. The operator can then use the sandblast hose as a powerful blower to clean parts or the booth floor by blowing media residue into the collection pits.

## WARNINGS

NEVER leave the sandblaster under pressure when not in use.

The diagram below illustrates the operating principle of the sandblaster and its various controls.

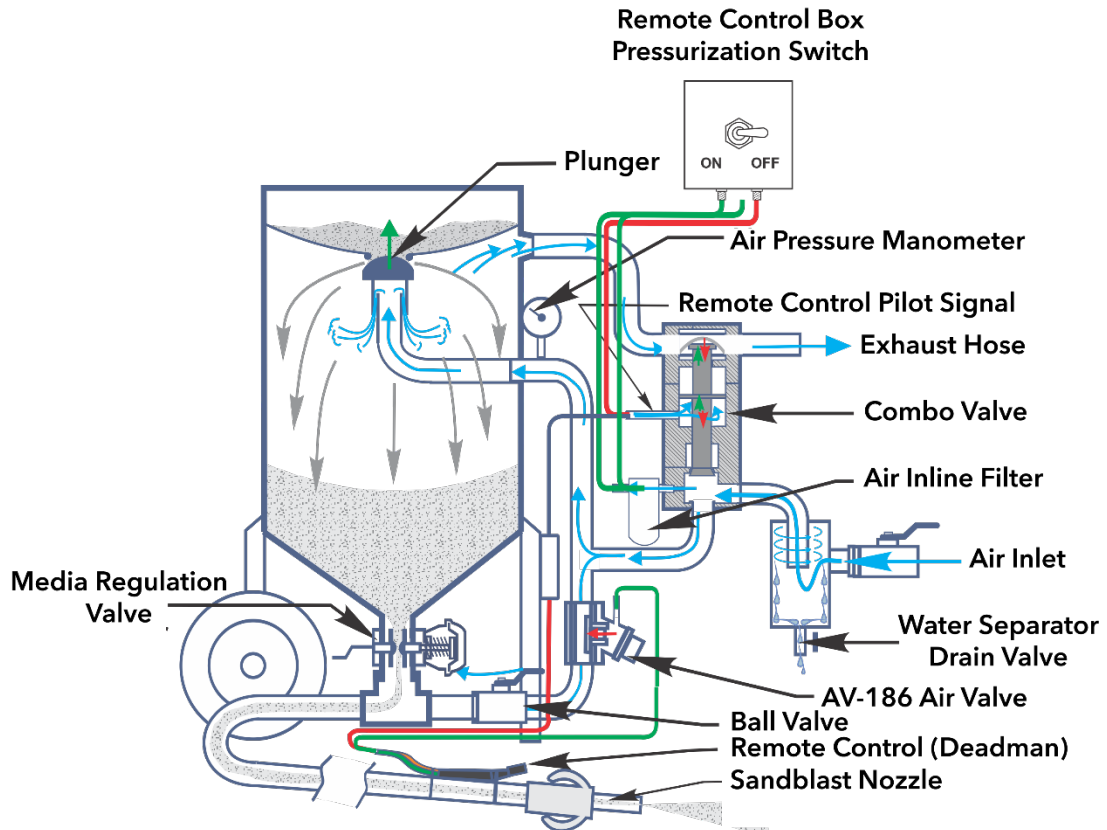



## ADJUSTING THE MEDIA REGULATION VALVE

The media regulation valve is located below the pressurized vessel. This valve controls the volume of abrasive media entering the thrust line and passing through the sandblast nozzle.

The ideal opening depends on the type and size of the media (grit size). For this reason, it is necessary to adjust the media control valve each time you change the abrasive media. It is not recommended to fully open or close the opening.

Kresco offers 3 media control valve models for its dual control sandblast pots.

Model	Type	Visual
<b>AR8 + Booster</b>	Normally closed pinch valve with actuator.	
<b>Corsa II</b>	Normally closed piston valve with urethane sleeve with piston and pneumatic pilot.	
<b>Thompson II XL</b>	Normally closed piston valve with urethane sleeve with piston and pneumatic pilot.	

### **PINCH VALVE (AR8 + Booster)**

You must activate the sandblasting function during the pinch valve adjustment to activate the actuator and release the pinch in the rubber tube. It is recommended that two people perform the adjustments: one to activate the sandblasting inside the booth (by pressing the control handle) and one to make the adjustments on the valve while the sandblast is running.

### **PISTON VALVE (Corsa II or Thompson II XL)**

You must make the piston valve adjustments WHEN SANDBLASTING IS STOPPED.

## **ADJUSTING THE MEDIA REGULATION VALVE**

To adjust the volume of media propelled into the system, turn the knob until the desired mixture is achieved.

- Turn the handle counterclockwise to add more media to the mix.
- Turn the handle clockwise to reduce the volume of media in the mix.

## **INITIAL ADJUSTMENT OF THE MEDIA REGULATION VALVE**

Follow the instructions below for the initial valve setting and make micro-adjustments as you become familiar with the system:

- Turn the control handle clockwise all the way to completely close the valve.
- Turn the control handle counterclockwise for two and a half (2-1/2) turns - this is your initial starting position
- Press the remote-control handle to activate the sandblasting and observe the result for 10 to 15 seconds.
- Adjust by a quarter turn at a time in either direction to adjust as needed
  - If no discoloration is visible and a high-pitched sound is coming from the sandblasting nozzle, this means there is not enough abrasive in the mixture and the volume of abrasivemedia should be increased by turning the control handle counterclockwise.
  - If the sandblasting nozzle feed is irregular and jerky, this means there is too much abrasive in the mixture and the abrasive flow rate should be reduced by turning the control handle clockwise.

**ALLOW APPROXIMATELY 15 SECONDS OF SANDBLASTING OPERATIONS BETWEEN EACH ADJUSTMENT** to see the difference because the sandblasting hose contains media from the previous setting.

## **DESIRED ADJUSTMENT**

The sandblasting output from the nozzle should be slightly colored, misty, and steady. The effect on the workpiece should be rapid and effective (when the abrasive is new). The flow should not be jerky or unstable.

# SANDBLASTER OPERATION

## SANDBLASTER PRESSURIZATION

Before pressurizing the sandblaster, ensure that the following conditions are met:

1. All "BEFORE SANDBLASTING" procedures were followed.
2. The air inlet valve is closed
3. The remote-control handle is released
4. All hoses are properly connected and have a safety tie installed.
5. The sandblaster is set up in a safe and levelled location, where everyone in the neighborhood is informed and vigilant about its presence
6. Anyone near the sandblaster must wear the required safety equipment
7. Only personnel who have been thoroughly trained by Kresco and who have read and understood the manual may be near the sandblaster

When these conditions are met, open the compressed air supply located on the Air Inlet manifold and then set the "Pressurization/Depressurization" switch to "Pressurized". The sandblaster is now ready for operation.

### **!HAZARD!**

Never perform maintenance or attempt to open the sandblaster while it is pressurized. The violent release of compressed air and propelled objects can cause serious injury or death.

Never supply compressed air at a pressure greater than 150 psi to the sandblaster.

### **WARNINGS**

The sandblast hose can create a kickback when the remote-control handle is activated. Be prepared for this kickback.

### **WARNINGS**

All those who will be in the area during sandblasting must be well trained, have read the manual and wear safety equipment to protect themselves against hazards.

## **BEFORE STARTING SANDBLASTING OPERATIONS**

Refer to the OPERATING PRINCIPLE to familiarize yourself with how it works.

When using the sandblaster for the first time, an adjustment of the abrasive valve is necessary. Refer to the MEDIA REGULATION VALVE ADJUSTMENT procedure to fully understand the adjustment procedures.

Make sure you wear the appropriate personal protective equipment (PPE). Kresco representatives can guide you in choosing the right system to operate the sandblaster safely.

## **HOW TO OPERATE THE SANDBLASTER**

Once the sandblaster is pressurized, you are now ready to sandblast.

1. Position yourself approximately 1 meter from the part to be sandblasted.
2. Position the sandblasting hose on your shoulder so that you can support its weight.
3. Point the sandblasting nozzle towards the area to be sandblasted at a striking angle of approximately 45 degrees.
4. To start sandblasting, lower the safety lever on the remote-control handle and hold it down.
5. If necessary, when sandblasting is in operation, adjust the pressure regulator located at the compressed air supply inlet to the desired pressure.
6. Travel across the sandblasting area maintaining a constant speed and overlapping the trajectories.
7. Release the remote-control handle when moving or repositioning the sandblasting hose.

When the sandblaster runs empty:

8. Release the remote-control handle.
9. Return the "Pressurization/Depressurization" switch to "Depressurized" to depressurize the sandblaster.
10. Wait approximately 3-5 minutes to allow the media located in the storage hopper above to fill.
11. Return the "Pressurization/Depressurization" switch to "Pressurized" in order to pressurize the sandblaster.

You are now ready to continue the sandblasting operations.

## **STOP THE SANDBLASTER**

Once the sandblasting is complete:

1. Release the remote-control handle.
2. Return the "Pressurization/Depressurization" switch to "Depressurized" to depressurize the sandblaster.
3. Turn off the compressed air supply at the source (at the compressor).
4. Disconnect the air supply hose.
5. Close the ball valve on the air intake manifold.

**!HAZARD!**

Respiratory illnesses can result from airborne particles generated by abrasive blasting.

Anyone involved in or near the sandblasting operation must wear appropriate NIOSH/OSHA approved respiratory protection. Abrasives containing silica must NEVER be used.

**!HAZARD!**

When the sandblaster depressurizes, the compressed air suddenly and violently escapes from the exhaust valve. Be aware.

**WARNINGS**

Only people who have received complete training in sandblasting may use the sandblaster.

This manual provides only basic information on the safe use of the features of abrasive sandblasters.

**WARNINGS**

You should NEVER point the sandblasting nozzle at anyone, including yourself, or at the sandblasting pot.

**WARNINGS**

Ensure the non-return valve is fully open during sandblasting to avoid damaging the equipment.

## **AIR HOSE DISCONNECT**

After the sandblaster has been depressurized, and the main air valve closed, the compressed air hose from the compressor may still contain pressure which must be released before disconnecting the hose.

To do this, shut off the compressed air at its source and slowly open the inlet valve on the sandblaster.

The compressed air stored in the supply air hose can now be vented through the drain valve. When you no longer hear air escaping from the drain valve, squeeze the hose to confirm the absence of compressed air. Once the hose is clear, it is ready to be disconnected.

### **!HAZARD!**

Never disconnect a compressed air supply hose without first performing the AIR HOSE DISCONNECT procedure described above. Failure to do so may cause the hose to violently explode, injuring or killing people nearby.

# PREVENTIVE MAINTENANCE

## SANDBLASTER



### DAILY MAINTENANCE

Component	Additional information
Water separator	→ Empty the water separator regularly (8).
Sandblaster	→ Pressurize the sandblaster and perform a visual and auditory inspection to detect leaks (service door, plunger, plunger seal, plumbing, valves, etc.).

### MAINTENANCE EVERY 6 MONTHS

Component	Additional information
Drain hose	<ul style="list-style-type: none"> <li>→ Check the inside of the pressure relief valve (2) and replace it if necessary.</li> <li>→ Check the depressurization hose at the pinch point and replace it if necessary (4).</li> </ul>
Sandblaster sealing	<ul style="list-style-type: none"> <li>→ Check the wear on the plunger (11) and of the plunger seal (10).</li> <li>→ Replace if any signs of wear are visible and contact a Kresco representative to investigate the cause.</li> </ul>
Media regulating valve	<ul style="list-style-type: none"> <li>→ Perform a complete disassembly and maintenance of the media control valve (9).</li> <li>→ Check the urethane regulating tube of the AR8 media regulating valve (9) (if equipped). Replace it if necessary.</li> </ul>

### ANNUAL MAINTENANCE

Component	Additional information
Sandblaster sealing	→ Check the wear on the service door seal (12) and the sealing gasket of the sandblaster lid (1). Replace as needed.

**REPLACE IF NECESSARY**

#	Kresco Code	Description
1	ROL-NC1/2X1/8-S-ME	Closed-Cell Neoprene Foam, 1/2" Width x 1/8" Thickness
2	FIT-P1-1/4M-GA	Square Head Plug, Galvanized Steel, 1-1/4" NPTM
3	FLT-MINI-1/4	1/4" NPTF Inline Filter
4	SBH-3/4X1-1/2-BLK	SBH 3/4" x 1-1/2" OD Black Sandblast Hose
5	MAN-P-160P-B1/4-NM	Pressure Gauge 0-160 PSI Rear 1/4" NPT Thread, Unmounted
6	VAV-COMBO-1-1/4	1-1/4" Combo Valve
7	VAV-AIV-1-1/4	AV-176 1-1/4" Air Valve
8	PNA-SEP-1-1/2	1-1/2" Water Separator
9	AMV-CORSAII-1-1/4	Corsa II Abrasive Regulation Valve 1-1/4"
	AMV-AR8-BOOSTER-1-1/4	AR8 1-1/4" Abrasive Regulation Valve with Actuator
	AMV-AR-TUBE	Rubber Tube for AR7 and AR8 Abrasive Regulation Valves
10	VPA-POP-4-RING	Sealing Gasket for SBP-350/650 Plunger
	VPA-POP-4-7/8-RING	SBP-1050 Plunger Seal
11	VPA-POP-4-PLUNGER	4" Plunger for SBP-350/650 Sandblaster
	VPA-POP-5-PLUNGER	5" Plunger for SBP-1050 Sandblaster
12	GAK-SBP-DOOR-GASKET	SBP 5-1/2X7-1/2 Access Door Seal SBP-350/650/1050

## SANDBLASTING EQUIPMENT



### DAILY MAINTENANCE

Component	Additional information
Personal protective equipment (PPE)	→ Inspect the personal protective equipment ①. Maintain or replace as needed.
Sandblasting hose	→ Position the sandblasting hose ② in order to avoid overlaps and overly sharp curves.

### WEEKLY MAINTENANCE

Component	Additional information
Remote-control handle	→ Inspect and maintain the remote-control handle ②.
Sandblasting hose	→ Inspect the sandblasting hose ②. Look for signs of wear or leakage and replace if necessary
Sandblasting nozzle	→ Inspect the sandblasting nozzle ③ and replace as needed.
'Whip' section of the sandblasting hose	→ Inspect the 'whip' hose ④ for leaks and replace it if necessary. The "whip" type hose has a thinner wall for easier handling but wears out faster than regular sandblast hose.

### MONTHLY MAINTENANCE

Component	Additional information
Sandblasting line	→ Inspect the sandblasting hose ②, the fittings and their sealing gaskets ⑥ for signs of premature wear or leakage. → Replace them if necessary.
Personal protective equipment (PPE)	→ Inspect the breathing air supply hose ⑦ fittings and seals for weak points and premature wear. → Replace them if necessary.

# SPARE PARTS LIST

## SANDBLASTING HOSES, FITTINGS AND NOZZLES

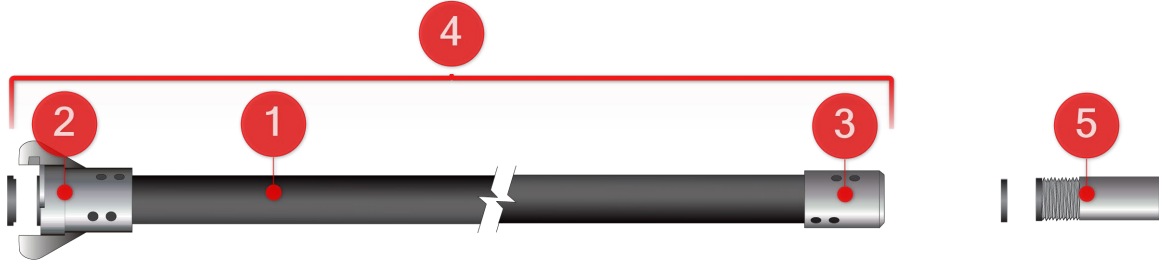

#	Description
1	Sandblasting hoses
2	Quick-release hose fittings (Chicago) and O-rings
3	Threaded nozzle fittings and O-rings
4	Factory-assembled hose and fitting kit
5	Threaded nozzles

### 1. SANDBLAST HOSES

Bulk sandblast hoses are sold in multiples of 25'.

Whip-type hoses (including the suffix -W) offer lightness and flexibility, but wear out faster because their wall thickness is smaller than standard hoses. Whip hoses are generally used as the "last length" of sandblast hose in sandblast booths and require more frequent replacement.



Kresco Code	Model	Inner Diameter	Outer Diameter
SBH-1X1-7/8	SBH-1	1"	1-7/8"
SBH-1-1/4X2-5/32	SBH-1-1/4	1-1/4"	2-5/32"
SBH-1-1/4X1-7/8-W	SBH-1-1/4-W	1-1/4"	1-7/8"
SBH-1-1/2X2-3/8	SBH-1-1/2	1-1/2"	2-3/8"
SBH-2X2-7/8	SBH-2	2"	2-7/8"

## 2. QUICK-DISCONNECT HOSE FITTINGS (CHICAGO)

Quick disconnect hose fittings (Chicago) are sold with a rubber sealing gasket.



Kresco Code	Description	Compatibility with sandblasting hoses
COU-BHQC1-AL	Quick-disconnect (Chicago) 1"	SBH-1 and SBH-1-1/4-W
COU-BHQC1-1/4-AL	Quick-disconnect fitting (Chicago) 1-1/4"	SBH-1-1/4
COU-BHQC1-1/2-AL	Quick-disconnect fitting (Chicago) 1-1/2"	SBH-1-1/2

## 2. SEAL FOR HOSE FITTINGS



Kresco Code	Description	Compatibility with sandblasting hoses
GAK-COU-1	Quick-disconnect fitting (Chicago) 1/2" sealing gasket	SBH-1/2-W and SBH-3/4
GAK-COU-1-1/4	Quick-disconnect fitting (Chicago) 3/4" sealing gasket	SBH-1/2 and SBH-3/4-W
GAK-COU-1-1/2	Quick-disconnect (Chicago) 1" sealing gasket	SBH-1 and SBH-1-1/4-W

### 3. THREADED NOZZLE FITTINGS

The fittings below are compatible with 1-1/4" NPS or 50 mm threaded nozzles. Aluminum fittings are stronger than nylon ones, but it can sometimes be more difficult to remove a worn nozzle due to abrasive media that can become lodged in the threads if the nozzle is not installed correctly.

#### NYLON



Casing Model	Nozzle Compatibility (Thread)	
	50MM	NPSF
SBH-1	COU-NHHC1-50MM-NY	COU-NHHC1-NPSM-NY
SBH-1-1/4	COU-NHHC1-1/4-50MM-NY	COU-NHHC1-1/4-NPSM-NY
SBH-1-1/4-W	COU-NHHC1-50MM-NY	COU-NHHC1-NPSM-NY

#### ALUMINUM

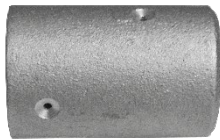

Casing Model	Nozzle Compatibility (Thread)	
	50MM	NPSF
SBH-1	COU-NHHC1-50MM-AL	COU-NHHC1-NPSM-AL
SBH-1-1/4	COU-NHHC1-1/4-50MM-AL	COU-NHHC1-1/4-NPSM-AL
SBH-1-1/4-W	COU-NHHC1-50MM-AL	COU-NHHC1-NPSM-AL

### 3. QUICK-DISCONNECT NOZZLE FITTINGS (CHICAGO)

The quick-disconnect threaded fitting is compatible with all NPSM 1-1/4" threaded nozzles. Nozzle not included. These nozzle fittings are primarily used by operators who frequently change nozzles, but this type of connection could cause wear on the hose and/or nozzle.



Kresco Code	Description
COU-THQC1-NPSF-AL	Quick-disconnect (Chicago) threaded NPSF 1-1/4" for 1" hose
COU-THQC1-1/4-NPSF-AL	Quick-disconnect (Chicago) threaded NPSF 1-1/4" for 1-1/4" hose
COU-THQC1-1/2-NPSF-AL	Quick-disconnect (Chicago) threaded NPSF 1-1/4" for 1-1/2" hose
COU-THQC2-NPSF-AL	Quick-disconnect (Chicago) threaded NPSF 1-1/4" for 2" hose

### 4. HOSES AND FITTINGS ASSEMBLY KITS



Kits with two hose connectors (QC-QC) on both ends can be used to make extensions. Sets with one hose connector (QC) and one nozzle connector (NH) are used to insert the nozzle.



Sandblasting Hose Model	Length	Available Kits (Kresco Codes)		
		QC-QC	QC-NH (NPS Thread)	QC-NH (50MM Thread)
SBH-1	12.5	HOK-1-QCQC-12.5	HOK-1-QCNH-12.5-NPS	HOK-1-QCNH-12.5-50MM
	25	HOK-1-QCQC-25	HOK-1-QCNH-25-NPS	HOK-1-QCNH-25-50MM
	50	HOK-1-QCQC-50	HOK-1-QCNH-50-NPS	HOK-1-QCNH-50-50MM
SBH-1-1/4	12.5	HOK-1-1/4-QCQC-12.5	HOK-1-1/4-QCNH-12.5-NPS	HOK-1-1/4-QCNH-12.5-50MM
	25	HOK-1-1/4-QCQC-25	HOK-1-1/4-QCNH-25-NPS	HOK-1-1/4-QCNH-25-50MM
	50	HOK-1-1/4-QCQC-50	HOK-1-1/4-QCNH-50-NPS	HOK-1-1/4-QCNH-50-50MM
SBH-1-1/4-W	12.5	HOK-1-1/4W-QCQC-12.5	HOK-1-1/4W-QCNH-12.5-NPS	HOK-1-1/4W-QCNH-12.5-50MM
	25	HOK-1-1/4W-QCQC-25	HOK-1-1/4W-QCNH-25-NPS	HOK-1-1/4W-QCNH-25-50MM
	50	HOK-1-1/4W-QCQC-50	HOK-1-1/4W-QCNH-50-NPS	HOK-1-1/4W-QCNH-50-50MM

## 5. SINGLE VENTURI SANDBLASTING NOZZLES

Single Venturi nozzles offer exceptional sandblasting performance. Their design is characterized by a narrow inlet and a wide opening, which significantly increases the velocity.

Materials	Kresco Code	Model	Internal Diameter	Thread
<b>Tungsten Carbide</b>  	NOZ-DCV3-3/16TUN	DCV3	3/16"	NPSM 1-1/4"
	NOZ-DCV4-1/4TUN	DCV4	1/4"	NPSM 1-1/4"
	NOZ-DCV5-5/16TUN	DCV5	5/16"	NPSM 1-1/4"
	NOZ-DCV6-3/8TUN	DCV6	3/8"	NPSM 1-1/4"
	NOZ-DCV7-7/16TUN	DCV7	7/16"	NPSM 1-1/4"
	NOZ-DCV8-1/2TUN	DCV8	1/2"	NPSM 1-1/4"
<b>Boron Carbide</b>  	NOZ-BCV3-3/16BOR	BCV3	3/16"	NPSM 1-1/4"
	NOZ-BCV4-1/4BOR	BCV4	1/4"	NPSM 1-1/4"
	NOZ-BCV5-5/16BOR	BCV5	5/16"	NPSM 1-1/4"
	NOZ-BCV6-3/8BOR	BCV6	3/8"	NPSM 1-1/4"
	NOZ-BCV7-7/16BOR	BCV7	7/16"	NPSM 1-1/4"
	NOZ-BCV8-1/2BOR	BCV8	1/2"	NPSM 1-1/4"

## 5. SEAL FOR SINGLE VENTURI NOZZLES

The NW1 sealing gasket is compatible with the majority of 1-1/4"NPS Venturi-type nozzles available on the market.



Kresco Code	Description
GAK-NW1	NW1 rubber sealing gasket for single Venturi type sandblasting nozzle

## 5. DOUBLE VENTURI SANDBLASTING NOZZLES

Double Venturi nozzles offer increased performance compared to single Venturi nozzles. The hole inside the nozzle allows atmospheric air to be drawn in, which significantly increases velocity while reducing velocity loss.

Materials	Kresco Code	Model	Internal Diameter	Thread
 <b>Boron Carbide</b>	NOZ-DVNB-3/16B-50MM	DVNB3	3/16"	50 mm
	NOZ-DVNB-1/4B-50MM	DVNB4	1/4"	50 mm
	NOZ-DVNB-5/16B-50MM	DVNB5	5/16"	50 mm
	NOZ-DVNB-3/8B-50MM	DVNB6	3/8"	50 mm
	NOZ-DVNB-7/16B-50MM	DVNB7	7/16"	50 mm
	NOZ-DVNB-1/2B-50MM	DVNB8	1/2"	50 mm

## 5. SEAL FOR DOUBLE VENTURI NOZZLES

The NW2 sealing gasket is compatible with Double Venturi type nozzles with a 50 mm thread. This gasket is inserted between the nozzle and the sandblasting hose.



Kresco Code	Description
GAK-NW2	NW2 rubber sealing gasket for double Venturi type sandblasting nozzle

## REMOTE-CONTROL HANDLE

### AIRFLOW PNEUMATIC CONTROL HANDLE

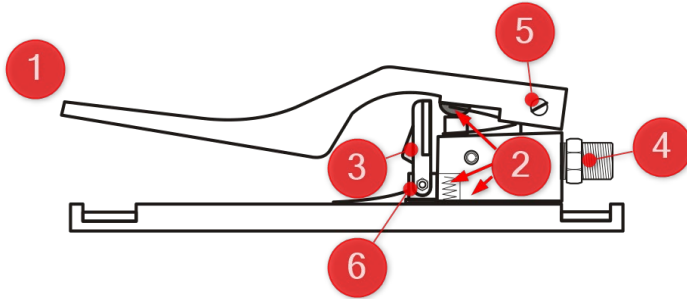

#	Kresco Code	Description
1	REM-0164	AirFlow Pneumatic Remote-Control Handle - NPT Thread
2	REM-0164-REPAIR	Repair kit Including a Spring, a Button and a Base
3	REM-0104-LEVER	Safety Valve
4	FIT-R1/4X1/8MM-HEX-BR	Reduced Brass Hex 1/4" NPTM x 1/8" NPTM
5	REM-0164-SPRING	Spring
6	REM-0164-SCREW	Shoulder Screw

### AIRFLOW ELECTRIC CONTROL HANDLE

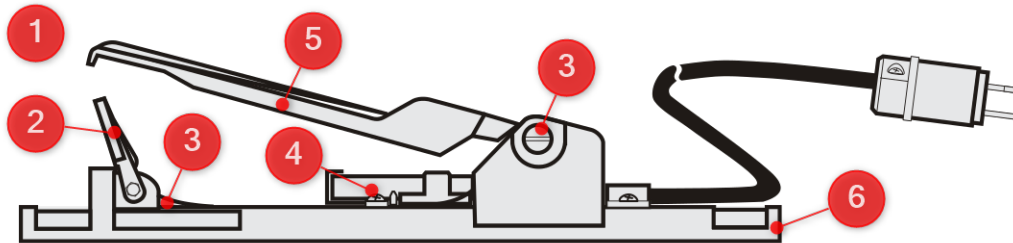

#	Kresco Code	Description
1	REM-0104	AirFlow Electric Remote-Control Handle - NPT Thread
2	REM-0104-LEVER	Safety Valve
3	REM-0164-SPRING	Spring
4	REM-0164-SWITCH	Switch
5	REM-0104-HANDLE	Clenche
6	REM-0164-BASE	Base
7	REM-0164-SCREW	Shoulder Screw

## PNEUMATIC-TO-ELECTRIC CONVERSION BOX

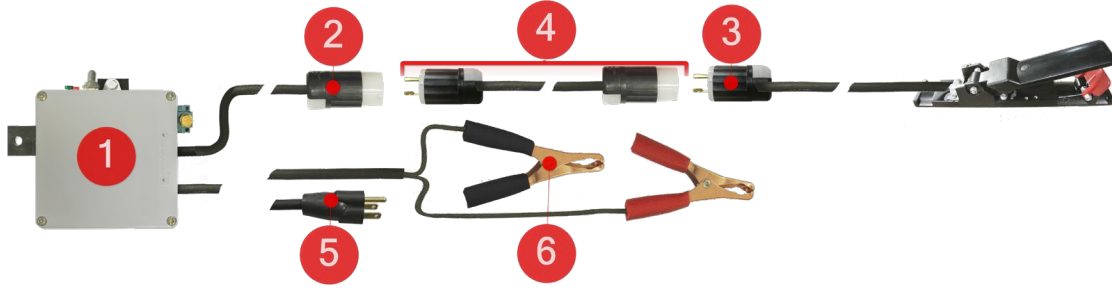

#	Kresco Code	Description
1	REM-ELE-BOX-12V	12V-Pneumatic Signal Conversion Box (includes ② and ⑥)
	REM-ELE-BOX-120V	120V-Pneumatic Signal Conversion Box (includes ② and ⑤)
2	PLG-5-15R-120V-LOCK	NEMA 5-15A 125V Lockable Female Socket
3	PLG-5-15P-120V-LOCK	NEMA 5-15A 120V Lockable Male Plug
4	REM-ELE-CABLE-12-1/2	12-1/2' Electrical Extension Cable with Male/Female Plugs
	REM-ELE-CABLE-30	30' Electrical Extension Cable with Male/Female Plugs
	REM-ELE-CABLE-55	55' Electrical Extension Cable with Male/Female Plugs
	REM-ELE-CABLE-105	105' Electrical Extension Cable with Male/Female Plugs
	REM-ELE-CABLE-130	130' Electrical Extension Cable with Male/Female Plugs
5	CAB-SJEOW-14-3-9M	14-3 SJEOW 9m Flexible Cable with Plug
6	HAR-CLIP-12V	12V Clamp

## EXTENSION FOR PNEUMATIC REMOTE-CONTROL HANDLE



#	Kresco Code	Description
1	FLX-TW-025-0030	1/4" Twin Green/Red Welding Hose 30'
2	FLX-TW-025-0055	1/4" Twin Green/Red Welding Hose 55'
3	FLX-TW-025-0070	1/4" Twin Green/Red Welding Hose 70'
4	FLX-TW-025-0080	1/4" Twin Green/Red Welding Hose 80'
5	FLX-TW-025-0090	1/4" Twin Green/Red Welding Hose 90'
6	FLX-TW-025-0105	1/4" Twin Green/Red Welding Hose 105'
7	FLX-TW-025-0115	1/4" Twin Green/Red Welding Hose 115'

## 1-1/4" COMBO VALVE

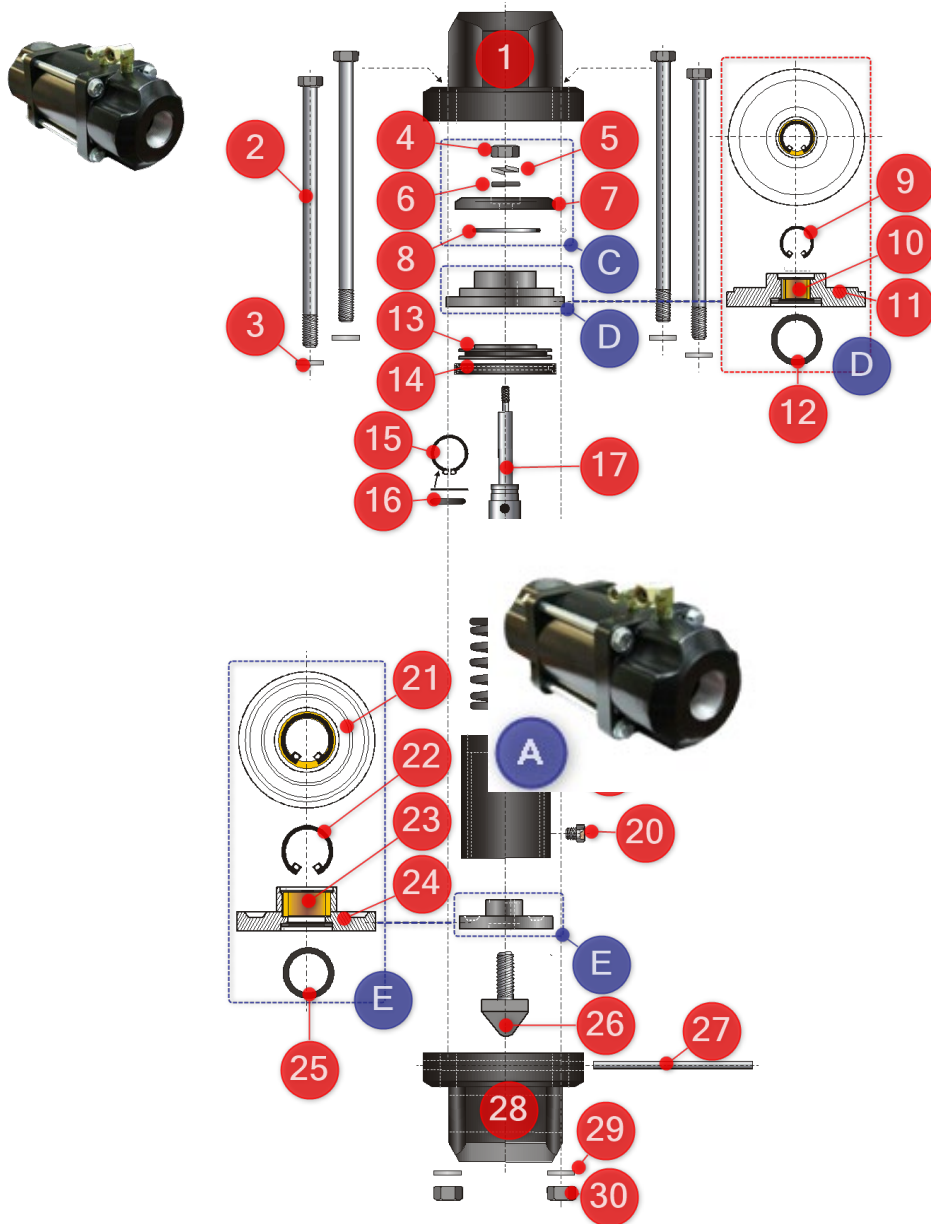

### VALVE & SERVICE KITS

#	Kresco Code	Description
HAS	VAV-COMBO-1-1/4	1-1/4" Combo Valve
B	VAV-COMBO-1-1/4-KIT	Repair Kit (4, 5, 6, 7, 12, 14, 15, 16, 22, 25)
C	VAV-COMBO-1-1/4-PLUGKIT	Set of Caps (4, 5, 6, 7, 8)
D	VAV-COMBO-1-1/4-UPASY	Upper Assembly (21, 22, 23, 25)
E	VAV-COMBO-1-1/4-DWASY	Lower Assembly (9, 10, 11, 12)

**SPARE PARTS**

#	Kresco Code	Description
1	VAV-COMBO-1-1/4-CAP	Lid
2	N/A	Hex Head Bolt
3	N/A	Flat Washer
4	N/A	Lock Nut
5	N/A	Curved Spring Washer
6	N/A	O-Ring
7	N/A	Seat
8	N/A	Flat Washer
9	N/A	Circlip
10	N/A	Lower Rod Guide Ring
11	N/A	Lower Stem Guide
12	N/A	Lower Stem Joint
13	N/A	Piston
14	N/A	Piston Seal
15	N/A	Circlip
16	N/A	O-Ring
17	N/A	Axis
18	VAV-COMBO-1-1/4-SPRING	Spring
19	N/A	Cylinder
20	VAV-COMBO-1-1/4-MUFFLER	Exhaust Filter
21	N/A	Upper Stem Guide
22	N/A	Circlip
23	N/A	Upper Rod Guide Ring
24	N/A	Upper Stem Guide
25	N/A	Upper Stem Joint
26	N/A	Pinching Pin
27	N/A	Stem
28	VAV-COMBO-1-1/4-BASE	Base
30	N/A	Nut

## AV-186 AIR VALVE

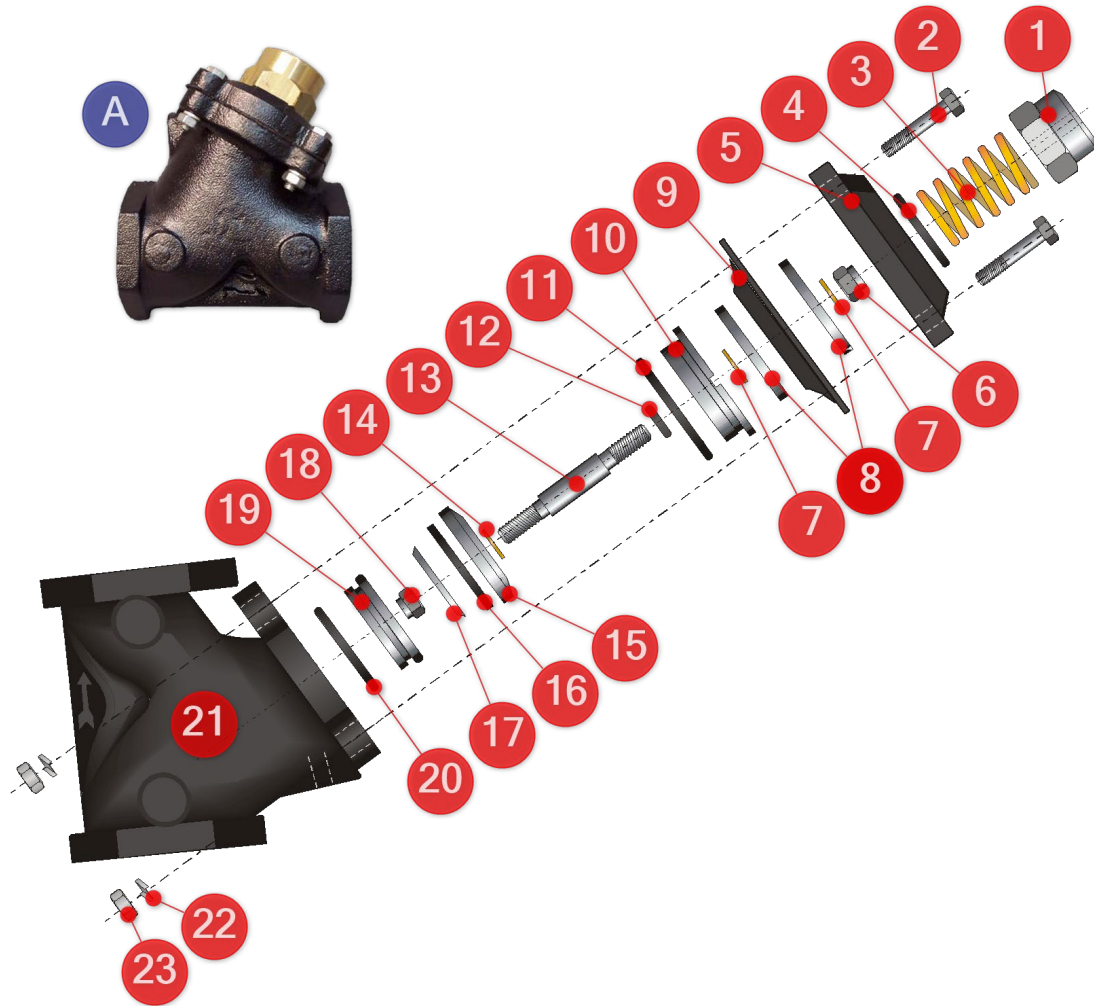

### VALVE & SERVICE KITS

#	Description	1-1/4"	1-1/2"
HAS	AV-186 Air Valve Complete Assembly	VAV-AIV-1-1/4	VAV-AIV-1-1/2
B	Repair Kit (4, 6, 7, 9, 11, 12, 14, 16, 18, 20)	VAV-AIV-1-1/4-KIT	VAV-AIV-1-1/2-KIT

**SPARE PARTS**

#	Kresco Code	Description
1	N/A	Hat
2	N/A	Hex Screw. Machined 1/4" UNC X 35 mm
3	VAV-AIV-SPRING	Spring
4	N/A	O-Ring 31.5 X 2 mm
5	N/A	Lid
6	N/A	5/16" Unf Lock Nut
7	N/A	8 mm Flat Washer
8	N/A	Flat Washer
9	N/A	Diaphragm
10	VAV-AIV-SERKIT-SL	Guide Sleeve
11	N/A	O-Ring 45 X 3 mm
11	N/A	O-Ring 45 X 3 mm
12	N/A	O-Ring 9 X 2.65 mm
13	N/A	Axis
14	N/A	Flat Washer
15	N/A	Base of Command
16	N/A	Rubber Seal
17	N/A	Bowl
18	N/A	1/2" UNF Lock Nut
19	N/A	Inner Ring
20	N/A	O-Ring 34 X 1.8 mm
21	N/A	Body
22	N/A	1/4" Spring Washer

# MEDIA REGULATION VALVE

## CORSA II

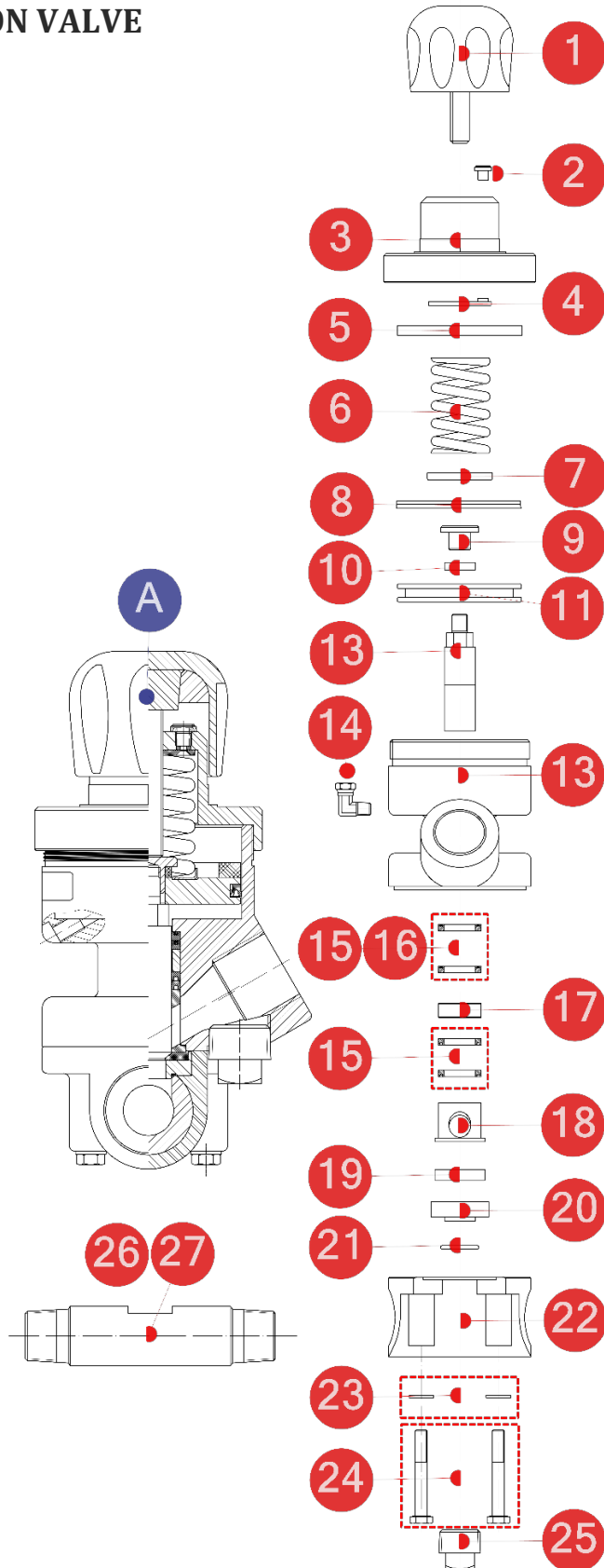

## VALVE & SERVICE KITS

#	Description	1-1/4"	1-1/2"
HAS	Corsa II Abrasive Regulation Valve	AMV-CORSAII-1-1/4	AMV-CORSAII-1-1/2
B	Seat Repair Kit (includes 19, 20 and 21)	AMV-CORSAII-KIT-SEAT	
C	Sealing Gasket Set (includes 8, 15, 16, 17, 18, 19, 20, 21)	AMV-CORSAII-KIT-SEAL	
D	Piston Repair Kit (includes 4, 5, 6, 8, 9, 10 and 11)	AMV-CORSAII-KIT-PISTON	
E	Base Repair Kit (includes 22, 23 and 24)	AMV-CORSAII-KIT-BASE	

## SPARE PARTS

#	Kresco Code	Description
1	AMV-CORSAII-KNOB	Control Button
2	AMV-CORSAII-FILTER	Exhaust Filter
3	AMV-CORSAII-CAP	NPT Cap
4	AMV-CORSAII-WASHER-VIB	Anti-Vibration Washer
5	AMV-CORSAII-ORING-STOP	Lock Washer
6	AMV-CORSAII-SPRING	Spring
7	AMV-CORSAII-SPRING-SEAT	Seat Spring
8	AMV-CORSAII-PISTON-SEAL	Piston Seal
9	AMV-CORSAII-PLUNGER-COVER	Piston Cover
10	AMV-CORSAII-WASHER-NYLON	Nylon Washer
11	AMV-CORSAII-PISTON	Piston
12	AMV-CORSAII-PLUNGER	Tungsten Diver
13	AMV-CORSAII-CYLINDER	NPT Cylinder
14	AMV-CORSAII-ELBOW	Elbow with Nut - NPT
15	AMV-CORSAII-PLUNGER-SEAL	Diver Seal
16	AMV-CORSAII-ORING-PLUNGER	Plunger O-Ring
17	AMV-CORSAII-BUSH	Ring
18	AMV-CORSAII-SLEEVE	Tungsten Sleeve
19	AMV-CORSAIII-SEAT	Urethane Seat
20	AMV-CORSAII-SEAT-HOLDER	Seat Support
21	AMV-CORSAII-ORING-SEAT	Seat O-Ring
22	AMV-CORSAII-BASE	NPT Base
23	AMV-CORSAII-WASHER-FLAT	Flat washer
24	AMV-CORSAII-BOLT	Hex Head Bolt
25	AMV-CORSAII-PLUG	Plug - NPT - Stainless Steel

#	Kresco Code	Description
26	AMV-CORSAII-N1-1/4	1-1/4" x 1-1/4" NPT Hose Fitting
27	AMV-CORSAII-N1-1/2	1-1/2" x 1-1/2" NPT Hose Fitting

### AR8 + BOOSTER

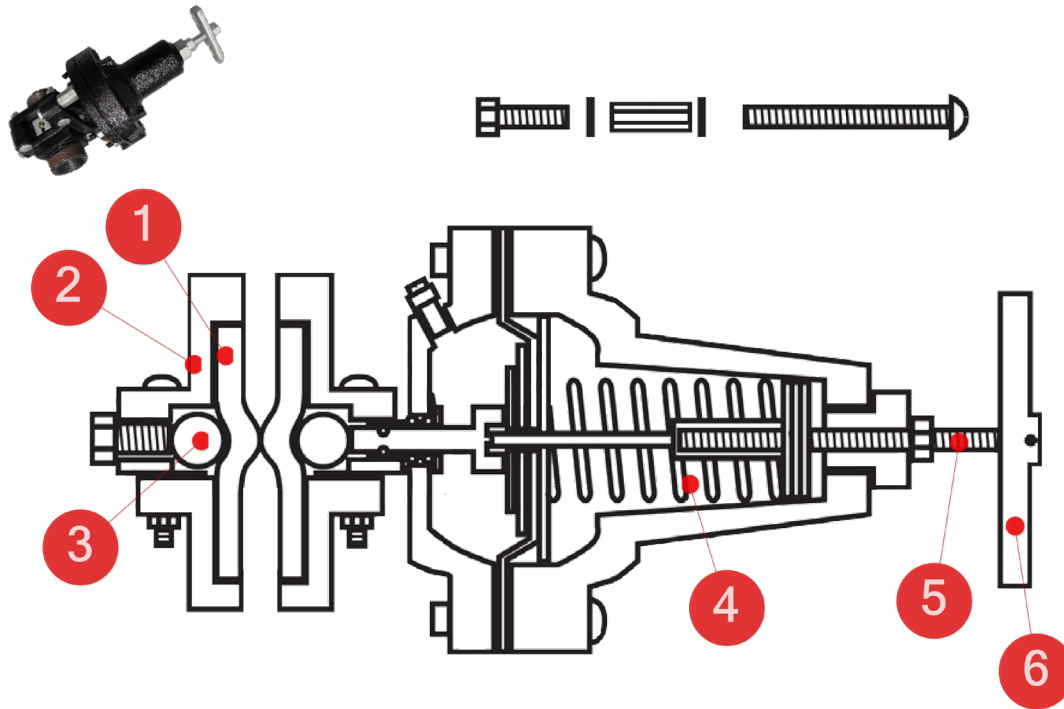

### SPARE PARTS

#	Kresco Code	Description
	AMV-AR8-1-1/4-BOOSTER	AR8 1-1/4" Abrasive Regulation Valve with Actuator - Complete Assembly
1	AMV-AR-TUBE	Rubber Tube for AR7 and AR8 Valves
2	AMV-AR8-FLANGE	AR8 2" NPT Flange
3	AMV-AR8-ROLLER	AR8 Pinch Roller
4	AMV-AR8-SPRING	AR8 Spring
5	AMV-AR8-SHAFT	1/2" AR8 Handle Shaft
6	AMV-AR8-HANDLE	AR8 Grip, Includes Adjustment Screw

## TROUBLESHOOTING

Type of failure	Possible cause	Resolution
Insufficient abrasive in the mix (the nozzle is mainly blowing air)	1. The sandblast pot is empty.	Depressurize the pressure vessel, add more media, and check again.
	2. The "Sandblasting/Air Only" switch (if equipped) is set to "Air Only" mode and prevents abrasive from flowing.	Turn the switch to "Sandblasting" to allow the abrasive regulator to transfer the media into the push line.
	3. Incorrect setting of the media control valve (the setting is too restricted, not allowing enough abrasive media into the mixture).	Follow the <b>MEDIA CONTROL VALVE ADJUSTMENT</b> procedure and turn the knob slightly counterclockwise, 1/4 turn at a time, to allow more abrasive media into the mix.
	4. There is a blockage in the abrasive regulator.	Ask a second qualified person to help you. Activate the remote-control handle and have a qualified person alternate opening/closing the "choke valve" 3 to 5 times until the obstruction is cleared. Minor obstructions, such as paint chips, a bit of wet abrasive, or a piece of paper, will be forced through the abrasive regulator and out of the nozzle. Return the abrasive regulator to the required sandblasting setting and check if the obstruction has been cleared. If the blockage persists, release the remote-control handle, depressurize the pressurized vessel, and proceed to disassemble the regulator and manually remove the blockage.
	5. The pressurized vessel has an air leak and the pressure inside the vessel is lower than that of the thrust line.	Check for air leaks (plunger seal, maintenance hatch and/or quick depressurization valve) and maintain your sandblasting pot.
	6. The abrasive media is contaminated by moisture, which prevents it from flowing through the regulator.	The wet abrasive must be removed. To do so, depressurize the sandblast pot, remove the access hatch assembly, and collect or vacuum up the wet abrasive mixture.  The sandblast pot should always be used with dry abrasive and supplied with clean, fresh, dry air to keep the abrasive dry. Consider maintaining and/or adding an air dryer and/or desiccant filter to your airline.

Type of failure	Possible cause	Resolution
<p>The abrasive flow is too strong or uneven during sandblasting</p>	<p>Note: When the quick depressurization system starts for the first time, they may vibrate for a while if there is an accumulation of abrasive in the sandblast hose from a previous operation. This is normal and no corrective action is necessary.</p>	
	<p>1. The choke valve is partially closed. The sandblasting pot must ONLY be used with the choke valve fully open.</p>	<p>Fully open the choke valve and check again.</p>
	<p>2. Incorrect setting of the media regulation valve (the setting is too open, leaving too much abrasive media in the mixture).</p>	<p>Follow the <b>MEDIA REGULATION VALVE ADJUSTMENT</b> procedure and turn the knob clockwise slightly, 1/4 at a time, to allow less abrasive media in the mix. *If your device is equipped with an actuator that closes the regulator when the device is not sandblasting, make sure to adjust the regulator only during sandblasting.</p>
<p>The pressure at the nozzle is too low</p>	<p>3. The rubber tube inside the regulator is worn or punctured.</p>	<p>Disassemble the regulator, clean any media buildup inside the regulator and replace the rubber tube. If the tube has a perforation, the media can flow freely into the regulator and cause wear on all other internal mechanical parts. Perform a complete inspection of the push line before using the unit again.</p>
	<p>1. The air compressor is too weak or the charging button is not activated.</p>	<p>Check your compressor or contact a Kresco representative.</p>
	<p>2. The nozzle is worn, creating an excessively high demand that the compressor is unable to supply.</p>	<p>Follow the maintenance procedure for your sandblasting nozzle and replace your nozzle if necessary. Consult the air consumption chart for pressure systems if needed.</p>
	<p>3. The air supply hose for the sandblaster is too small.</p>	<p>The internal diameter of the blasting hose must match the diameter of your pipe and valve outlets. Replace your sandblast hose or contact your Kresco representative.</p>
	<p>4. There is a hole in the sandblasting hose.</p>	<p>Follow the maintenance procedure for your sandblasting hose and replace it if necessary.</p>
	<p>5. The plunger valve does not close properly.</p>	<p>Follow the maintenance procedure on your sandblasting pot and change your plunger and/or plunger seal to ensure there are no leaks in your pressurized vessel.</p>
<p>6. There is one or more leaks in the maintenance access door assembly.</p>	<p>Perform a complete maintenance on your sandblast pot and replace your access door seal if necessary.</p>	

	7. The air intake valve is dirty or blocked.	Follow the maintenance procedure for your air valve and repair or replace as needed.
	8. The lower piston (if equipped) of the air inlet valve is damaged, defective or worn.	
	9. The choke valve is partially closed. The sandblasting pot must ONLY be used with the choke valve fully open, in order to avoid damaging it.	Open your choke valve and check again.
	10. The AR7/AR8 abrasive regulation valve is too open.	Follow the maintenance procedure for your AR7/AR8 abrasive regulation valve. Either the rubber tube must be replaced, or the valve must be inspected in case of failure.
	11. The nozzle is blocked.	Follow the maintenance procedure for your sandblasting nozzle and replace your nozzle if necessary.
The sandblaster starts accidentally or unexpectedly	1. The safety lever, remote-control handle or handle lock button is damaged or missing.	Immediately close the air inlet valve on your sandblasting pot and contact your Kresco representative.
The sandblaster stops too slowly or does not stop when the remote-control handle is released	1. The remote-control handle is defective, damaged or worn.	Repair or replace your remote-control handle.
	2. The electrical cable or pneumatic power hose of the remote-control handle is defective, damaged, or worn.	Replace your electrical cable or your pneumatic supply hose.
	3. The air valve (if applicable) needs repair due to insufficient lubrication, or it is blocked, defective, damaged or worn.	Follow the maintenance procedure for your air valve and replace it if necessary.
	4. The combo valve assembly (if fitted) does not release properly because it is defective, damaged or worn.	Follow the maintenance procedure for your combo air valve and replace it if necessary.
The sandblaster won't start or is slow to start	1. The air compressor is too weak or the charging button is not activated.	Check your compressor or contact a Kresco representative.
	2. The nozzle is worn, creating too much demand on the compressor.	Follow the maintenance procedure for your sandblast nozzle and replace it if necessary.
	3. The compressed air supply to the sandblaster is subject to restrictions.	The inside diameter of the compressed air supply hose on your sandblaster is too small, or quick-connect fittings are being used that cause air to escape. Replace your sandblasting hose or contact your Kresco representative.

4. There is one or more leaks in the control hoses and/or fittings.	Perform a complete maintenance check of your sandblasting pot and sandblasting nozzle.
5. The sandblasting nozzle is partially or completely blocked.	Follow the maintenance procedure for your sandblasting nozzle and replace it if necessary.
6. The air intake valve is dirty or blocked.	Follow the maintenance procedure for your air valve and replace it if necessary.
7. The remote-control handle is defective, damaged or worn.	Repair or replace your remote-control handle.
8. The electrical cable or pneumatic power hose of the remote-control handle is defective, damaged, or worn.	Replace your electrical cable or your pneumatic supply hose.
9. The power source (battery or AC-DC converter) does not generate enough power to open the electric control valves (if equipped).	Repair the power converter housing or replace it if necessary.
10. The control valve (if fitted) requires maintenance due to insufficient lubrication, or it is blocked, defective, damaged or worn.	Follow the maintenance procedure for your air valve and repair or replace as needed.

## WARRANTY STATEMENT

**Kresco** warrants all equipment led in this manual which is manufactured by **Kresco** and bearing its name, to be free from defects in material and workmanship on the date of sale by an authorized **Kresco** distributor to the original purchaser for use. Notwithstanding any special, extended or limited warranty published by **Kresco** will, for a period of TWENTY-FOUR (24) months from the date of sale, repair or replace any part of the equipment determined by **Kresco** to be defective.

This warranty applies only when the equipment is installed, operated and maintained in accordance with **Kresco's** written recommendations. This warranty DOES NOT cover, and **Kresco** shall not be liable for general wear and tear, or any malfunction, damage or wear caused by faulty installation, misapplication, abrasion, corrosion, inadequate or improper maintenance, negligence, accident, tampering, or substitution of non-**Kresco** component parts. Nor shall **Kresco** be liable for malfunction, damage or wear caused by the incompatibility with **Kresco** equipment with structures, accessories, equipment or materials not supplied by **Kresco**, or the improper design, manufacture, installation, operation or maintenance of structures, accessories, equipment or materials not supplied by **Kresco**.

This warranty is conditioned upon the prepaid return of the equipment claimed to be defective to an authorized **Kresco** distributor for verification of the claimed defect. If the claimed defect is verified, **Kresco** will repair or replace free of charge any defective parts. The equipment will be returned to the original purchaser, transportation prepaid. If the inspection of the equipment does not disclose any defect in material or workmanship, repairs will be made at a reasonable charge, which charges may include the costs of parts, labor, and transportation.

THIS WARRANTY IS EXCLUSIVE, AND IS IN LIEU OF ANY OTHER WARRANTIES, EXPRESSED OR IMPLIED, INCLUDING BUT NOT LIMITED TO WARRANTY OF MERCHANTABILITY OR WARRANTY OF FITNESS FOR A PARTICULAR PURPOSE.

**Kresco's** sole obligation and the buyer's sole remedy for any breach of warranty shall be as set forth above.

The buyer agrees that no other remedy (including, but not limited to, incidental or consequential damages for lost profits, lost sales, injury to person or property, or any other incidental or consequential loss) shall be available. Any action for breach of warranty must be brought forward within two (2) years of the date of sale.

**Kresco** MAKES NO WARRANTY, AND DISCLAIMS ALL IMPLIED WARRANTIES OF MERCHANTABILITY AND FITNESS FOR A PARTICULAR PURPOSE, IN CONNECTION WITH ACCESSORIES, EQUIPMENT, MATERIALS OR COMPONENTS SOLD BUT NOT MANUFACTURED BY **Kresco**. These items sold, but not manufactured by **Kresco** (such as electric motors, switches, hose, etc.), are subject to the warranty, if any, of their manufacturer. **Kresco** will provide the purchaser with reasonable assistance in making any claim for breach of these warranties.

## LIMITATION OF LIABILITY

In no event will **Kresco** be liable for indirect, incidental, special or consequential damages resulting from **Kresco** supplying equipment hereunder, or the furnishing, performance, or use of any products or other goods sold hereto, whether due to a breach of contract, breach of warranty, the negligence of **Kresco**, or otherwise.

Report all accidents or "near misses" which involve **Kresco** products to:

- Kresco Technical Assistance at 1-877-757-3726

The following items are not covered under the **Kresco** warranty policy:

- Parts or chassis replacement due to normal wear
- Consumables and replacement parts (hoses, nozzle, gaskets, etc.)

Defective material or workmanship is not considered normal wear

## ABOUT KRESCO

**Kresco** designs, manufactures, and supports industrial equipment for the surface treatment industries. **Kresco** has standard equipment designed for most applications and can customize equipment to meet or exceed your production expectations.

## SANDBLASTING

- Sandblast Booths
- Sandblast Cabinets
- Automated Sandblasting Systems
- Abrasive Reclaiming Systems
- Pressurized Sandblasters
- Dust Collectors

## SHOT BLASTING

- Roller Conveyor Blaster
- Rotary Table Blaster/Swing Table Blaster
- Spinner Hanger (Batch)
- Continuous Flow with Monorail.
- Rubber and Steel Flight Tumbler Blasters
- Flow Thru Barrel Blasters
- Mesh Belt Continuous Blasters
- Monorail System Blasters
- Rim Blasters
- Preservation Line

## PAINTING & COATING

- Paint Spray Booths
- Powder Coating Booths
- Drying Ovens

## SOLVENT RECOVERY

- Batch Solvent Distillers
- Continuous Flow Solvent Distillers
- Oil Cooling Systems

## PARTS & CONSUMABLES

- Blast Nozzles
- Blast Hoses
- Abrasive Media (Glass Bead, Aluminum Oxide, Steel Shot and Grit)
- Air Valves
- Abrasive Metering Valves
- Cartridge Filters
- Sludge Bags
- Safety Equipment & PPE

## SERVICES

- Turnkey Project Design
- Custom Design
- Full Installation
- Start-up Supervision
- Training
- Maintenance
- Retrofit & Upgrade

All systems are designed to build and they are manufactured with the highest quality standards in our manufacturing shop in Quebec, Canada.